



MACH3 USB Card NVUMv2.1

Manual

Contents

Chapter 1. Introduction.....	- 1 -
1.1 Product Introduction.....	- 1 -
1.2 Products specification.....	- 1 -
1.3 Products Appearance an struction and size.....	- 2 -
1.4 substantival explanation.....	- 3 -
1.5 Noting and Waring.....	- 5 -
Chapter 2. Connection.....	- 6 -
2.1 Device Power supply Solution.....	- 6 -
2.2 Product connection define and method.....	- 7 -
Chapter 3. Software Installation.....	- 20 -
3.1 MACH3 Install.....	- 20 -
3.2 MACH3 Registration.....	- 23 -
3.3 NVUM Plug-in installation.....	- 23 -
Chapter 4. Setting of software.....	- 24 -
4.1 Open software.....	- 24 -
4.2 Software Common settings.....	- 25 -
Chapter 5. Using of software.....	- 34 -
5.1 Set Machine Coordinate system.....	- 34 -
5.2 Set workpiece coordinate system.....	- 36 -
5.3 Open G code file and run.....	- 38 -
Chapter 6. Question & Answer.....	- 40 -
6.1 Q&A for Hardware.....	- 40 -
6.2 Q&A for Software.....	- 40 -
Chapter 7. Contract us.....	- 41 -

Chapter 1. Introduction

1.1 Product Introduction

Novusun CNC has engaged in the Numerical control industry for 7 years, specialized in the research, development and production of various CNC controller systems with high quality and high reliability. We produce the Brushless DC motor, Stepper motor driver, and also 1 to 6 axis CNC motion controllers.

NVUMV2.1 is the 3-6 axis motion controller we spend 4 years to design.

NVUMV2.1 support Mach3 software and standard MPG, through USB to communicate with computer.

NVUMV2.1 motion controller adopts the ARM design framework. The ARM design includes communication, code analytic, underlying algorithm and pulse generation. Rational design, reliable control, convenient operation.

This manual introduces operation, connection and usage schedule of our professional motion controller for engraving machine. Through a lot of the drawing the users can learn quickly how to use this motion controller.

1.2 Products specification

- ◆ Support USB;
- ◆ 12 ports photoelectric isolated input interface for ordinary digital data;
- ◆ 10 ports photoelectric isolated output interface for ordinary digital data;
- ◆ 1 port 0-10V spindle speed analog output interface (can change to PWM output);

- can support 3-6 axis stepper systems, 200KHz pulse output for every axis;
- ARM motion control chip;
- main device is 12V-32VDC power supply input, current should be higher than 0.5A;
- Compatible with MPG input, support the digital display MPG from our company.

1.3 Products Appearance and size

NVUMV2.1 motion controller is with the sealed shell structure, there are 4pcs setting holes at the bottom. We can fix 4pcs 4mm diameter holes at the cabinet, and install the controller into the cabinet. The controller appearance as the Figure 1-1 and Figure 1-2 show:

The products overall size is 163.1mm*80.8mm*27.8mm;

The bottom install size is 101.4mm*39.5mm.

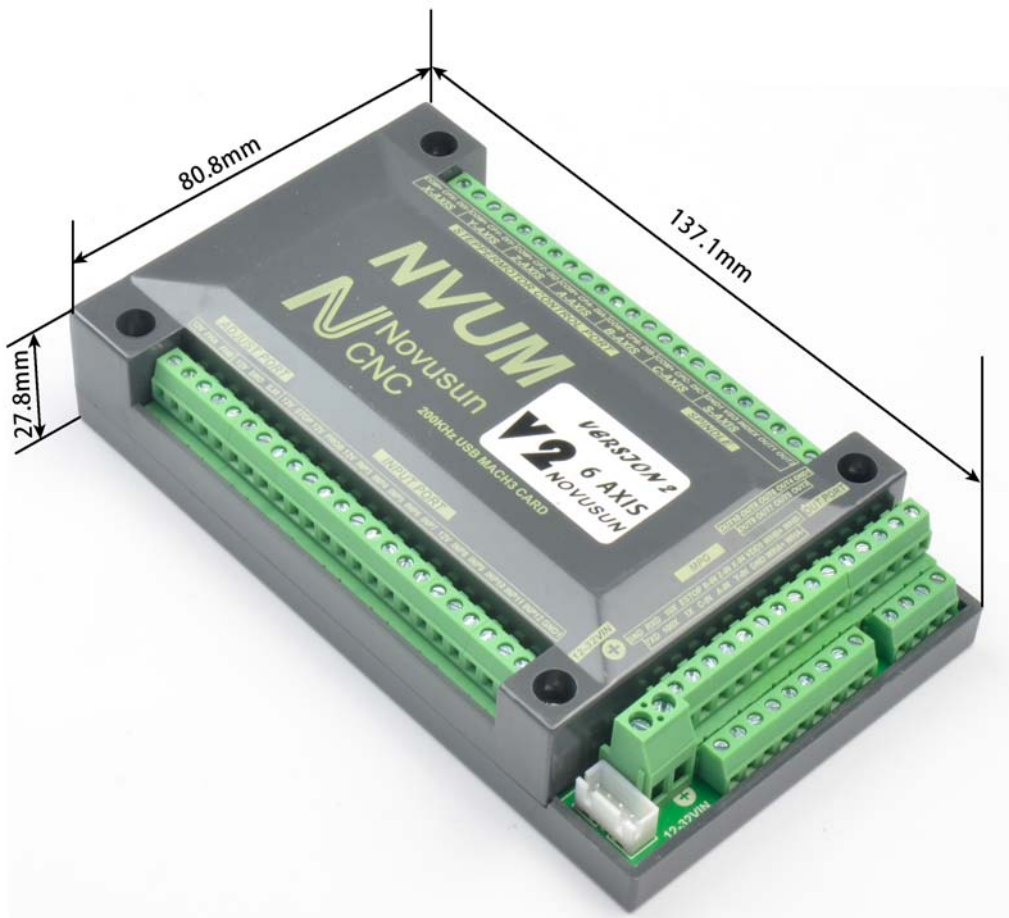

Figure 1-1. NVUMV2.1 front appearance and size

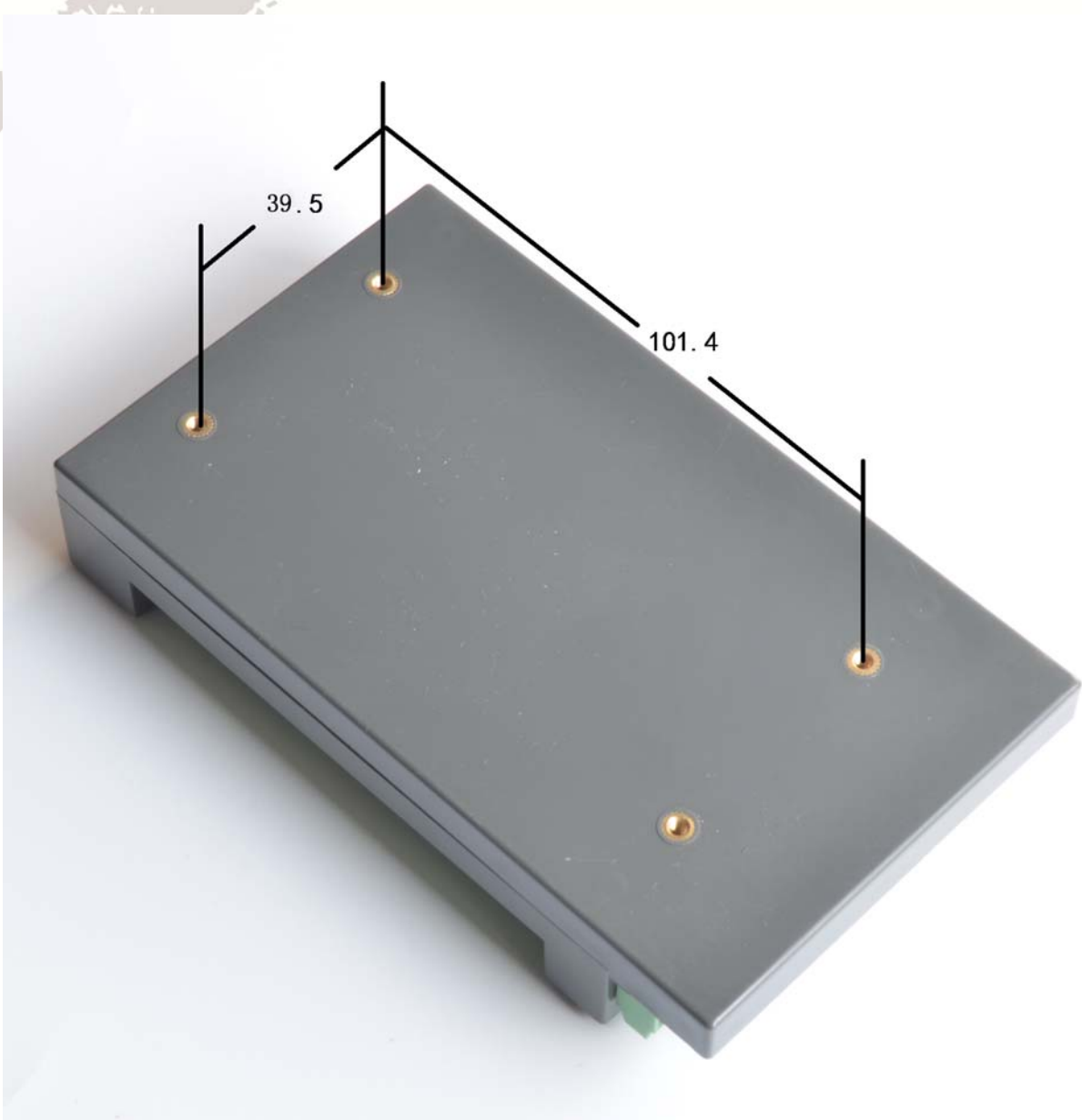

Figure1-2. The other side of NVUMV2.1 and installation dimensions

1.4 substantial explanation

When operate the NVUM, where will be a lot of English abbreviation, now we list all of them for your kindly references:

FRO: Feeding adjust: During the operating process, the F value already set, and need to adjust the current feeding speed, then we can adjust FRO value to realize it.

SRO: Spindle speed adjust: During the operating process, the S value already set, and need to adjust the current spindle speed, then we can adjust SRO value to realize it :

Current Speed $S\# = \text{setting } S * SRO$.

SRJ: speed adjust manually

During the operating process, as the manual speed already set, and we need to adjust the current speed, and impossible to fix the value during it is working, then we can revise the SRJ value to realize it.

Current manual speed $FS\# = \text{Setting manual speed} * SRJ$.

F: Feeding speed, the unit is mm/min. For example $F=200$, means every minute feeding 2000mm.

S: Spindle Speed. Unit is rad/min. For example $S=20000$, means 20000 revolution/Minute.

X axis Coordinate

Y axis Coordinate

Z axis Coordinate

A axis Coordinate

B axis Coordinate

C axis Coordinate

Ready: Ready Mode. In the mode we can do any operation, include processing or values modification or starting 2nd mode.

Reset: Reset mode. In this mode, it should stop every operation.

“Step”: Manual Step Mode. Every axis can conduct the manual step operation at this mode.

MPG: MPG mode. Every axis can conduct the MPG operation at this mode.

1.5 Noting and Waring



Free from exposure to the electronics without waterproof function. Please environment as dry as possible. This is the icon.



Wiring warning, the IO input terminal of this equipment support the equipment with source switch (such as Inductive proximity switch.) When using such kind of switch, attention please: avoid the +terminal and -terminal of power supply to connect with GND. This equipment's analogy quantity output terminal of spindle control also have a certain load capacity. Please avoid this terminal connect with GND. In case that the interior components and parts be broken down.



Operation warning, Please do the security measures well when connecting with the machine tools. The ESTOP, limit and other things must be perfected. When comes across the emergency, please press the ESTOP key at once or cut off the power directly, thus avoiding the equipment damage and casualty.



High voltage danger, the primary device is 18-32VDC power supply. Voltage equipment. Pls pay attention to the electricity, safety when conducting the operation

Chapter 2 | Connection

2.1 Device Power supply Solution

The power supply solution in the field of the Industrial automation is always very complicated, there is a lot of the GND, now we describe the structure of the power supply as below:

The power supply structure as the Figure 2-1, main power supply input and MPG module and stepper control output module are common GND, Limited and Estop input module and Spindle speed adjust M3/M8/M10 module are common GND, between main power supply and output module there are photoelectric isolation. The inputs of limited switch and Estop and so on are Common anode, inside of the device, there is +12VDC as common+, no need to connect external power supply. Based on the reference of output GND interface, output a 0-10V adjustable voltage to adjust the spindle speed, M3/M8/M10 digital output interface is open-GND. If connect an external relay, need to output GND to refer to, and give the relay an external power supply.

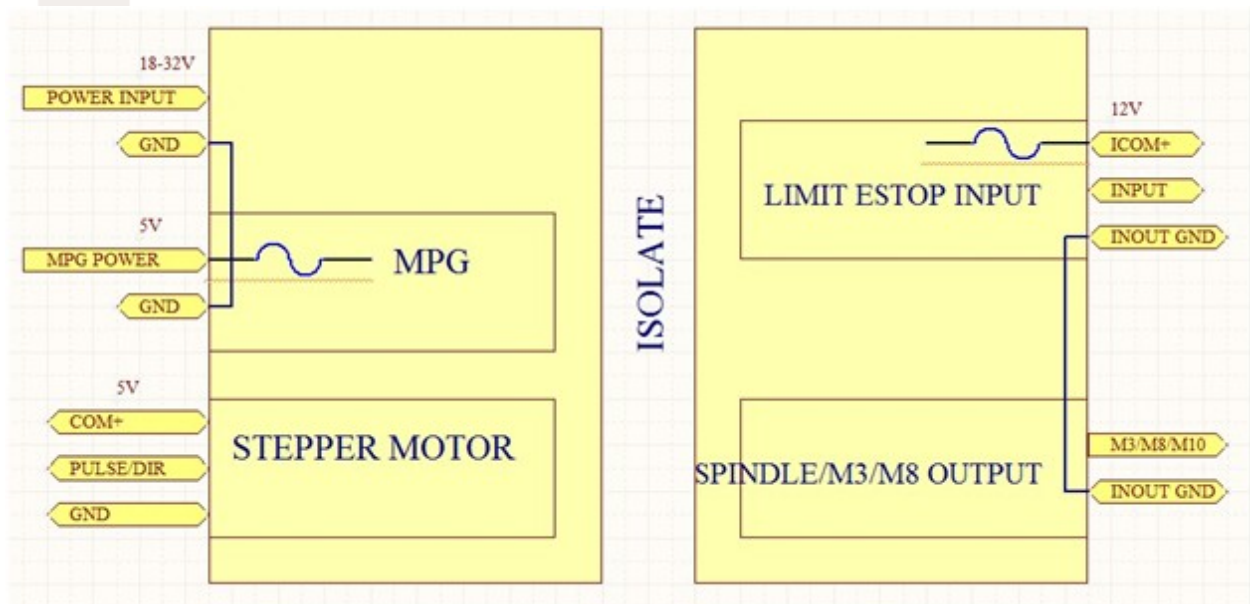

Figure2-1. Power supply structure of NVUM

2.2 Product connection define and method

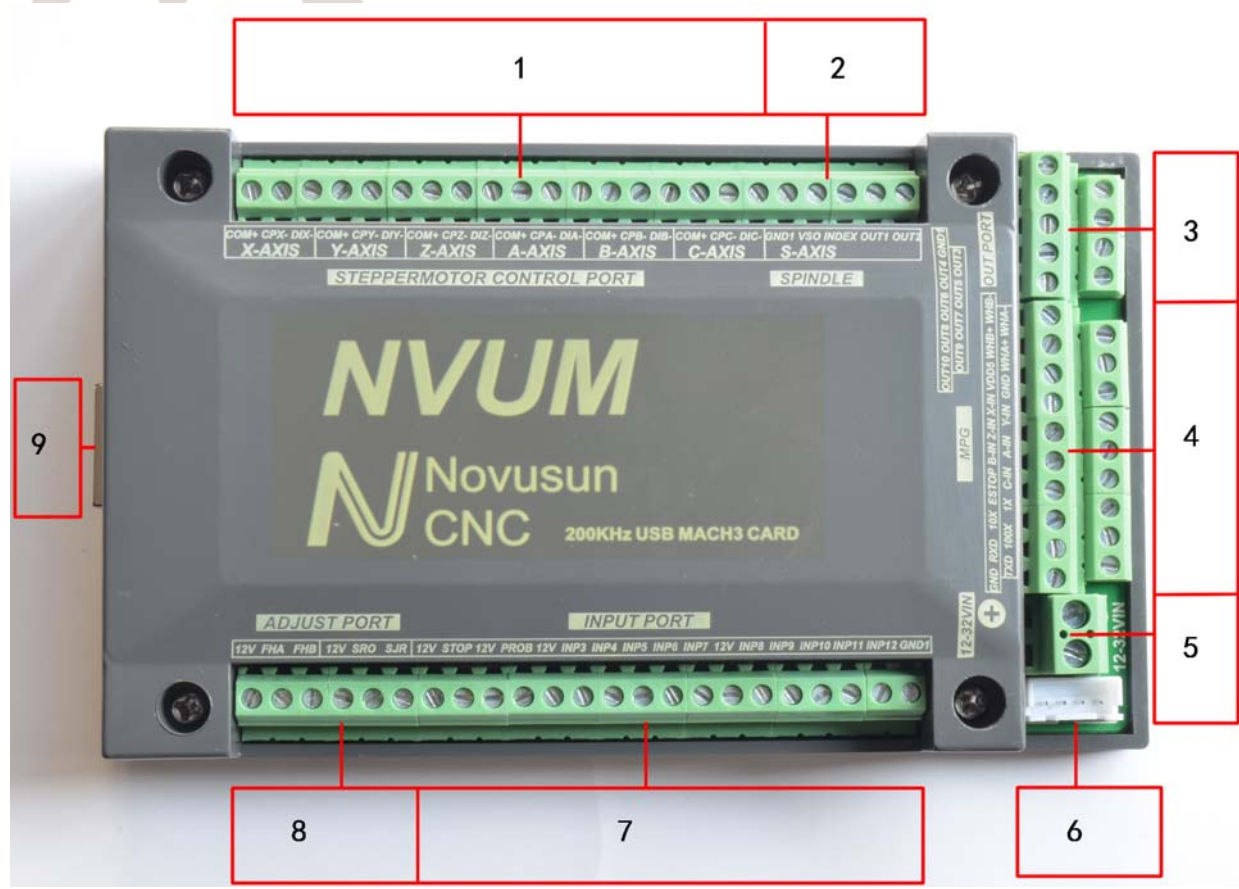

Figure2-2. Product wiring section and interface summary

As the Figure 2-2 showed,the connection of the controller includes power supply interface, USB connection interface, MPG interface, Stepper/Servo control output interface, spindle control output interface, Estop and limited switch and tool setting input interface and so on. Now we describe them in details as below.

2.2.1 Stepper motor control interface

As Figure 2-2 showed,No.1 terminal block is 6 axis stepper driver control output interface, from left to right, there are X,Y,Z,A,,B,C 6 axis output, it's common anode,the cable connection for each axis is COM+/CP-/DIR-, COM is common+ ,CP is Pulse-, DIR is direction-.Connection showed as Figure 2-3.COM+ connect with the SP+ and DIR+.

Pin mark	Axis	Definition
COM+	Common+	common anode +5V
CPX-	X axis	Pulse output- for X axis
DIX-	X axis	Direction output- for X axis
CPY-	Y axis	Pulse output- for Y axis
DIY-	Y axis	Direction output- for Y axis
CPZ-	Z axis	Pulse output- for Z axis
DIZ-	Z axis	Direction output- for Z axis
CPA-	A axis	Pulse output- for A axis
DIA-	A axis	Direction output- for A axis
CPB-	B axis	Pulse output- for B axis
DIB-	B axis	Direction output- for B axis
CPC-	C axis	Pulse output- for C axis
DIC-	C axis	Direction output- for C axis

Table 2-1. Stepper driver control interface define

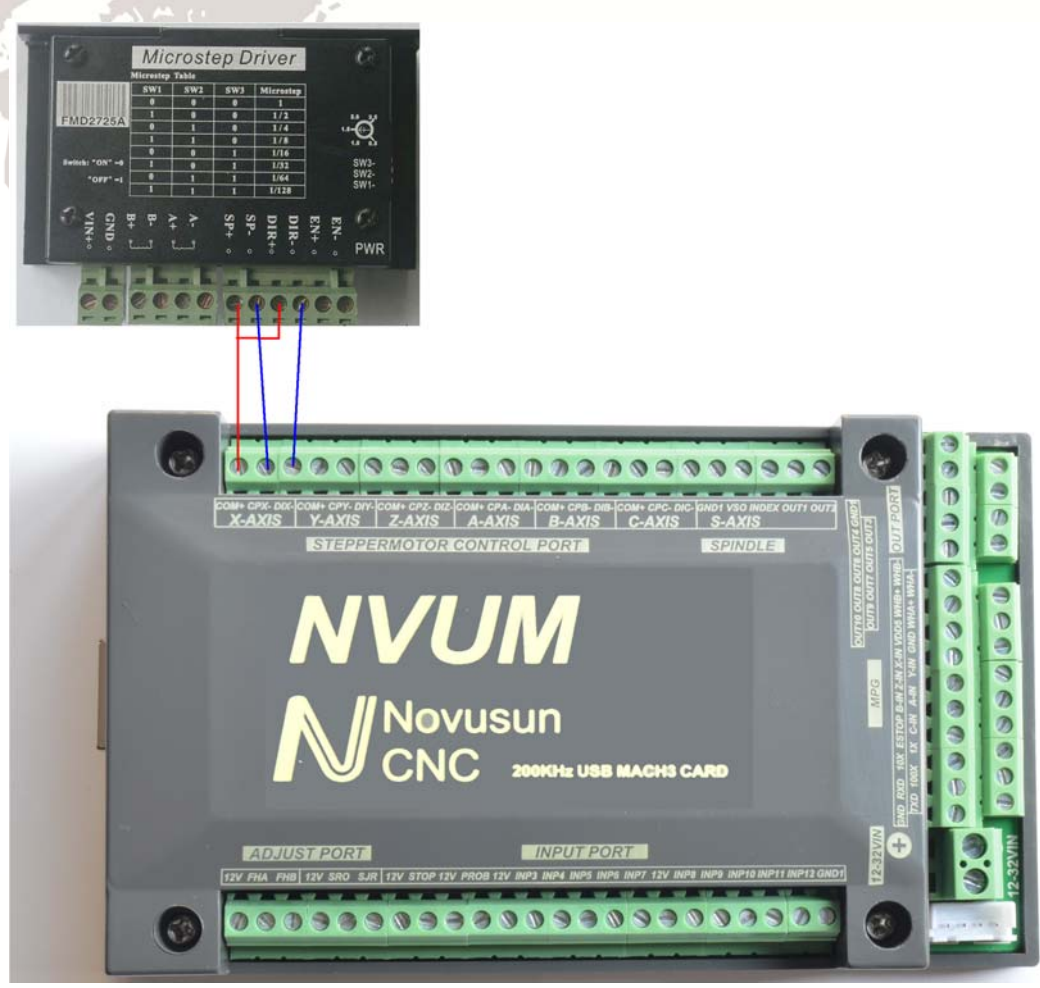

Figure 2-3. Stepper driver connection

2.2.2 Spindle control output

We define the interface from left are: GND1(Output GND),VSO(0-10V adjustable speed output),INDEX(spindle speed feedback input),OUT1(common output port 1),OUT2(common output port 2),.

Take Nowforeuer inverter as the example. Spindle control output and the inverter connection showed as Figure 2-4.If ACM and DCM are closed,only need to connect one port.

If need the Mach 3 to show the real in time spindle speed,just fix one hall device,every revolution send one pulse between INDEX and GND1,pulse voltage is 5V-10V.

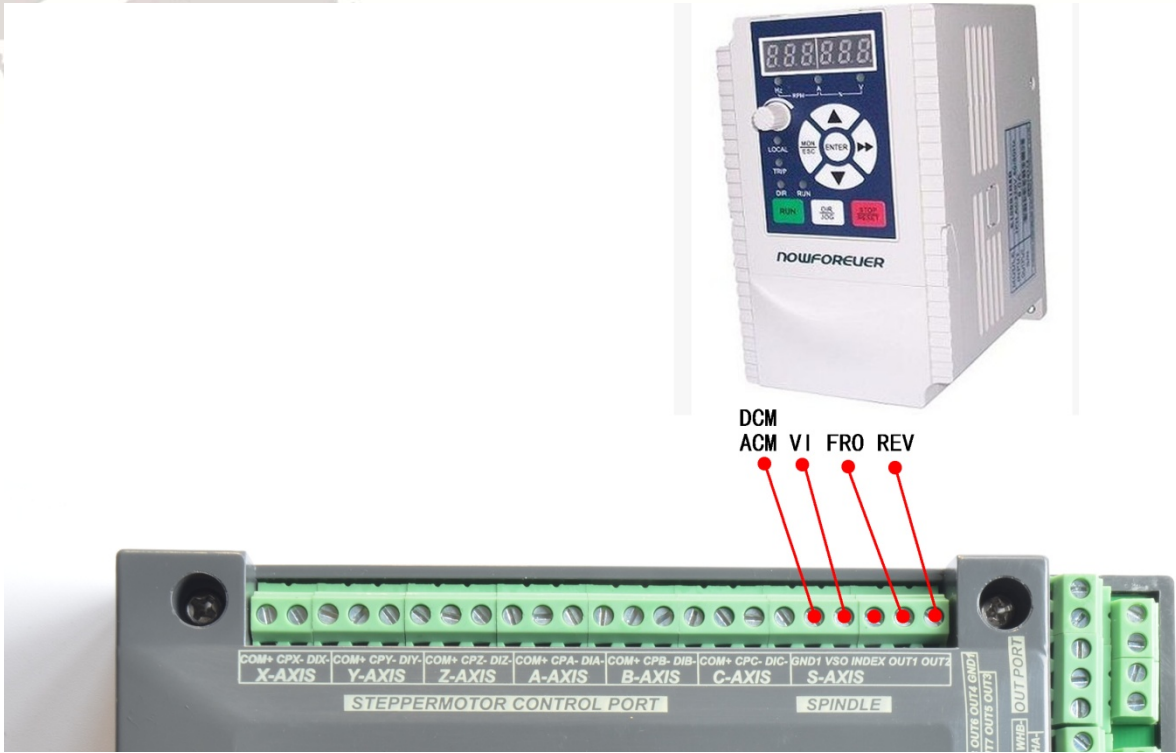

Figure2-4. spindle control output and inverter connection

VSO real output voltage=10V*s spindle setting speed/max spindle speed.Forexample,if max spindle speed is 24000,current spindle speed is S=18000,so the VSO output voltage=10*18000/24000=7.5V.

Max. spindle speed setting ports as showed sa Figure 2-5,open it from Pulley from Menu config.The current spindle speed can be set by S directive or Mach 3 spindle setting speed module.

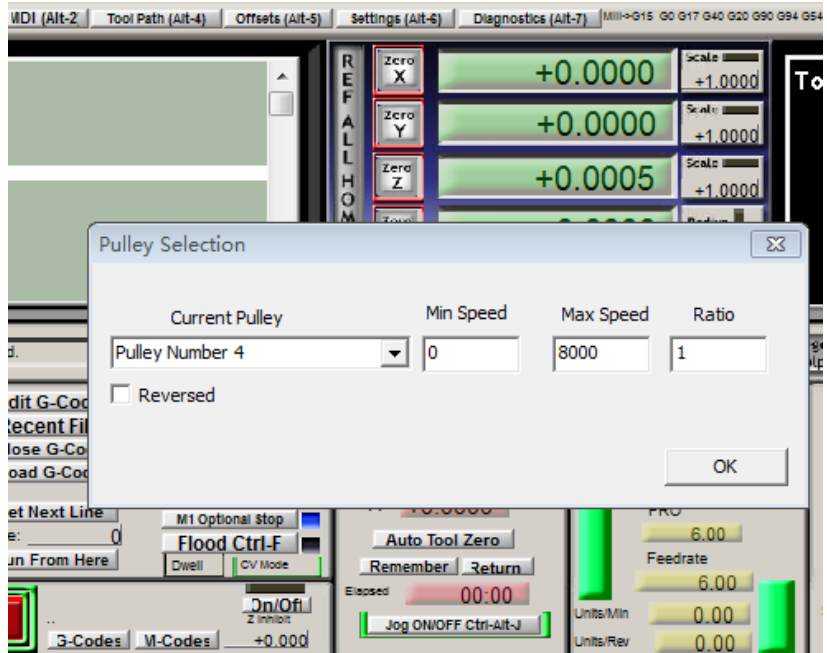

Figure2-5. Max spindle speed setting position

2.2.3 Common IO output interface

Common IO output include OUT1,OUT2 on the spindle interface,totally 10 ports IO output,open drainoutput,internal structure as Figure 2-6:

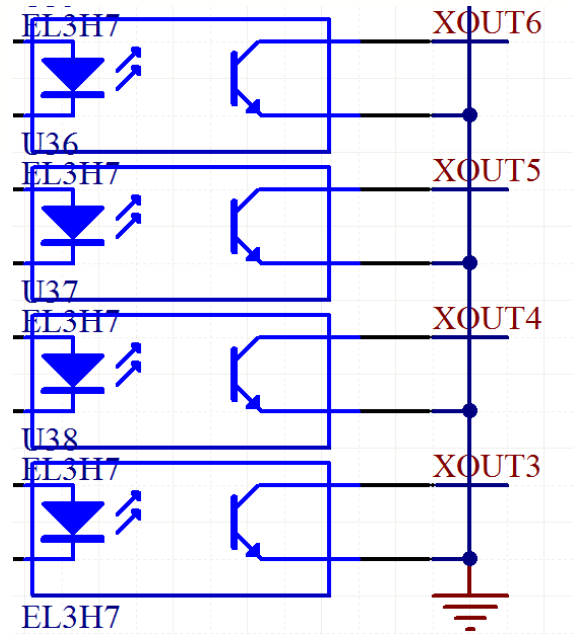

Figure2-6. OUT1-OUT10 internal structure

Now just make a switch between OUTX(X=1-10) and GND,to control the relay output,theconnection as the Figure 2-6.External power supply need to accord with the relay specification,the internal optocoupler GND open circuit only can absorb less than 50mA current,if relay absorb the current over 50mA,pls add current amplifier.In the Figure connect with OUT3,the others similar.

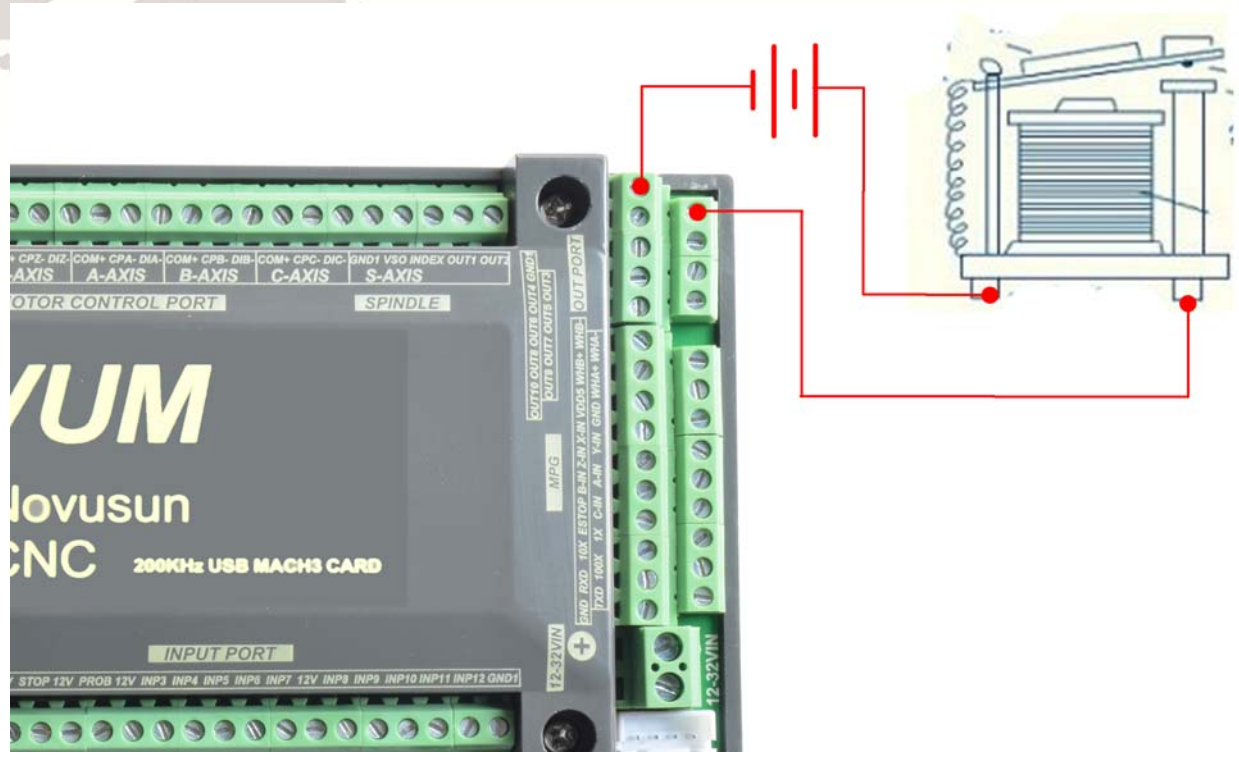

Figure2-7. OUTX connect with external relay method

2.2.4 MPG connection

The MPG port totally have 18 wiring terminals, and the reference of eachwiring terminal definition is table 2-2. The reference of corresponding relation between system and MPG wiring is table 2-3 and table 2-4.

Pin mark	Definition	Notes
GND	MPG Ground	MPG power supply GND.
TXD	MPG serial communication Output Port	For the digital display MGP communication
RXD	MPG serial communicationinput Port	For the digital display MPG communication
100X	100X multiplication switch	short connect with GND means 100X multiplication,cutoff means no pulse
10X	10X multiplication switch	short connect with GND means 10X multiplication,cutoff means no pulse

1X	1 X multiplication switch	short connect with GND means 1X multiplication,cutoff means no pulse
ESTOP	MPG Estop	short connect with GND means Estop effective,cutoff show invalid
C-IN	C Axis selected switch	Short connect with GND meanas selecting C aixe,cutoff means don't select
B-IN	B Axis selected switch	Short connect with GND meanas selecting B aixe,cutoff means don't select
A-IN	A Axis selected switch	Short connect with GND meanas selecting A aixe,cutoff means don't select
Z-IN	Z Axis selected switch	Short connect with GND meanas selecting Z aixe,cutoff means don't select
Y-IN	Y Axis selected switch	Short connect with GND meanas selecting Y aixe,cutoff means don't select
X-IN	X Axis selected switch	Short connect with GND meanas selecting X aixe,cutoff means don't select
VDD5	MPG power supply 5V output	MPG power supply 5V output
WHA+	MPG A Phases Positive	MPG A Phase differential Input Positive
WHB+	MPG B Phases Positive	MPG B Phase differential Input Positive
WHA-	MPG A Phases Negative	MPG A Phase differential Input Negative
WHB-	MPG B Phases Negative	MPG B Phase differential Input Negative

Table 2-2. NVUM on MPG' s define and explanation



NVUM PIN No.	MPG pin No. and color	
Estop	C	
1multiplication 1	X1	
10multiplication 10	X10	
100multiplication 100	X100	
X selecting	X	
Y selecting	Y	
Z selecting	Z	
A selecting	4	
B selecting	5	
C selecting	6	
A Phase +	A+	
A Phase -	A-	
B Phase +	B+	
B Phase -	B-	
GND	0V/CN/COM	
+5V-W	+5V	

Table 2-3. Connection between Differential MPG and NVUM

Note: It you want to use the single-terminal MPG (namely there is no A-B-MPG), please look at the wiring table, the table 2-4 for reference. As for the unlisted one, please take the differential MPG wiring mode.

NVUM Pin No.	MPG Pin No. and color
--------------	-----------------------

WHA+	A+	green
WHA-	0V	Black
WHB+	B+	white
WHB-	0V	Black

Table 2-4. Connection Between Single MPG and NVUM

2.2.5 Main power supply input Interface

As the Figure 2-2 show, No. 5 position interface is the main power supply input, marked “+” is the power supply positive, the other one wasn’t marked is the negative, power supply voltage is 12-32VDC, Current must be not less than 1A.

2.2.6 Communication external interface

As the Figure 2-2 showed, the marked No. 6 position is communication external port, this port wasn’t defined yet.

2.2.7 Estop limited Tool setting input interface

.As the Figure 2-2 showed, Marked No. 7 position is the Estop limited ect. they are the optical isolated Input interface, from the left, there are 12V, STOP, 12V, PROB, 12V, INP3, INP4, INP5, INP6, INP7, 12V, INP8, INP9, INP10, INP11, INP12, GND. Here STOP is INPUT1, and PROB is INPUT2. Internal structure Figure of Input interface see as Figure 2-8

ESTOP connect with NVUM see as Figure 2-9. Probe connect see as Figure 2-10

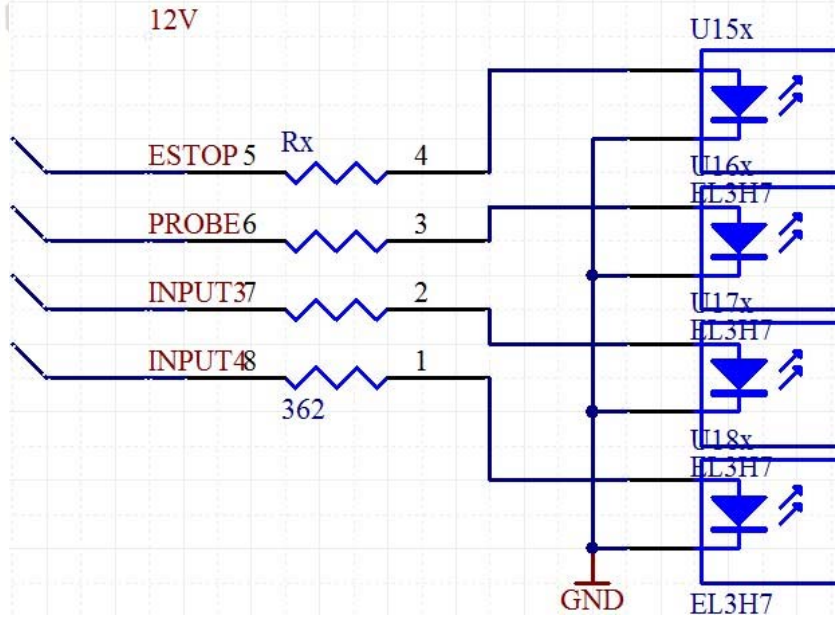

Figure2-8. Internal structure drawing of Input interface

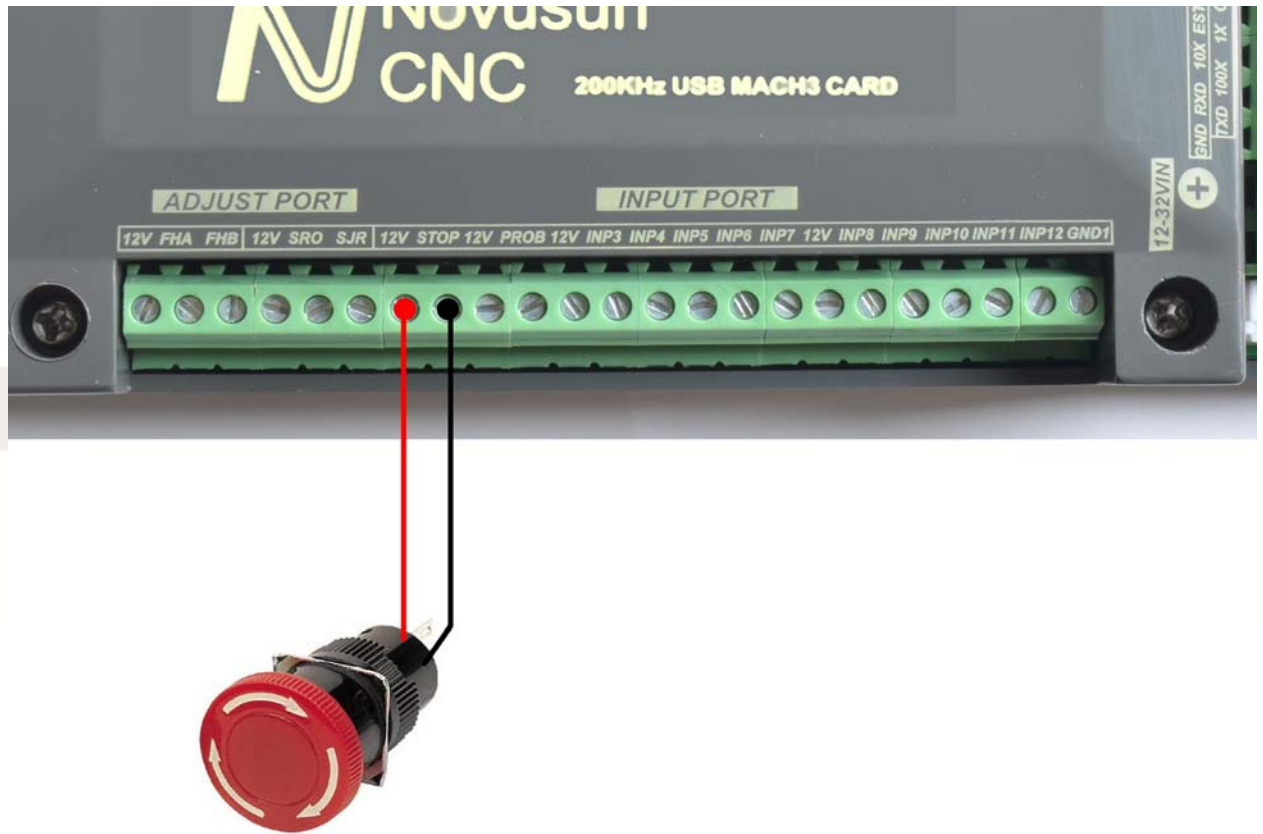

Figure2-9. Estop input connection

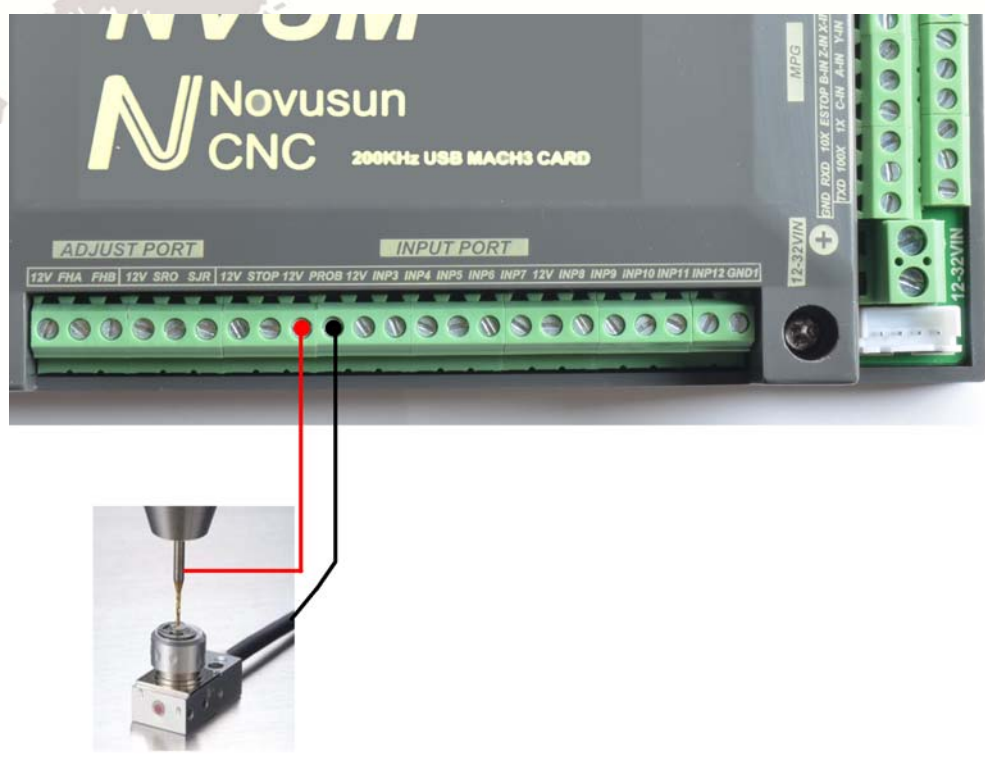

Figure2-10. Tool Setting Connection Drawing

2 lines Proximity Switch/ordinary frettingswitch drawing see as Figure 2-11



Figure2-11. 2 lines Proximity Switch/ordinary frettingswitch drawing

3 lines Proximity Switch connection Figure 2-12, brown cable for Proximity switch connect with 12V, Black cable connect channel, blue cable connect with GND1.

Only support PNP 3lines proximity switch.

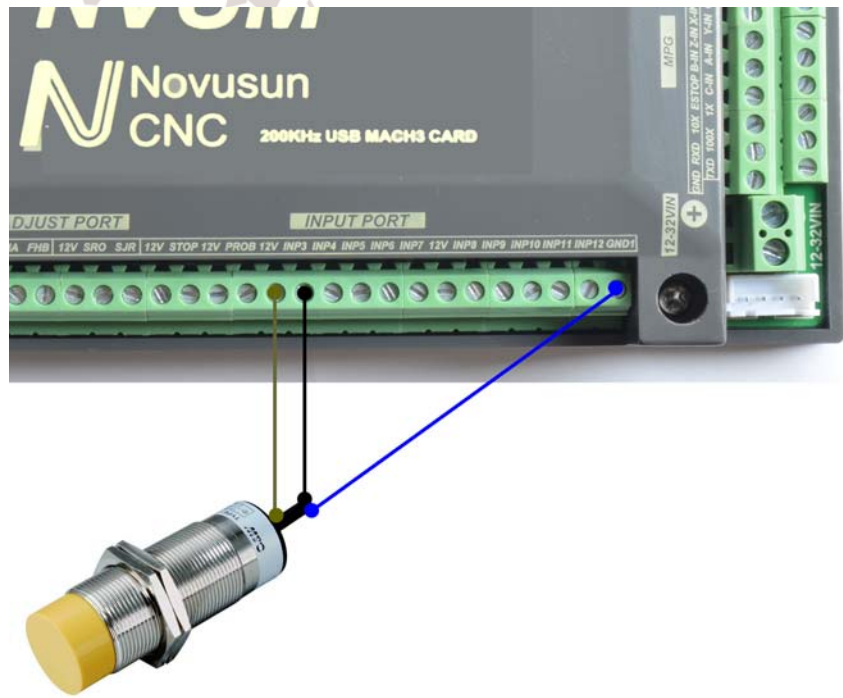

Figure2-12. PNP 3 lines Proximity Switch connection drawing

2.2.8 Parameter adjust interface

By this adjust interface, user can use a multi-position switch and a digital potentiometer (simple encoder) to modify FRO, SRO, and SJR. Wiring method see as figure 2-13. A simple encoder's COM, A, and B connect to 12V, FHA, and FHB, and a multi-position switch connect to 12V, SRO, and SJR. If 12V doesn't connect to SRO or SJR, the current effective parameter is FRO; if 12V connects to SRO, the current effective parameter is SRO; and if 12V connects to SJR, the current effective parameter is SJR.

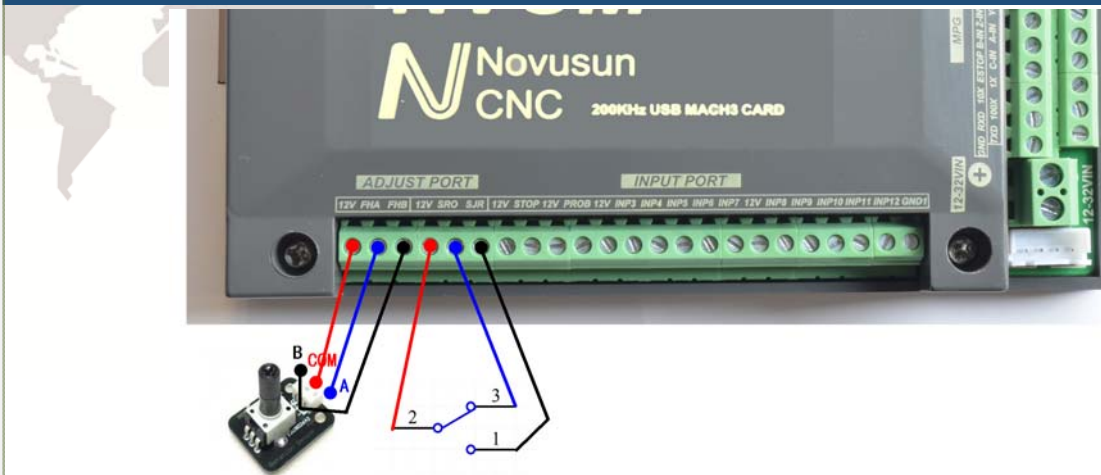

Figure2-13. Parameter adjust port

2.2.9 USB Port

As the Figure 2-2 show, The marked No. 9 port is USB communication port, NVUM communicate with mach 3 through it.



Chapter 3. Software Installation

3.1 MACH3 Install

When you purchase our product, we will supply a CD-ROM, which contains the MACH3 installation, registration, and USB plug-ins. See as Figure 3-1



Figure3-1. MACH3 soft installation

First run the installation Mach3Version3.043.066



Mach3Version3.043.066
Setup Application

.Into the first

page. See as Figure 3-2.

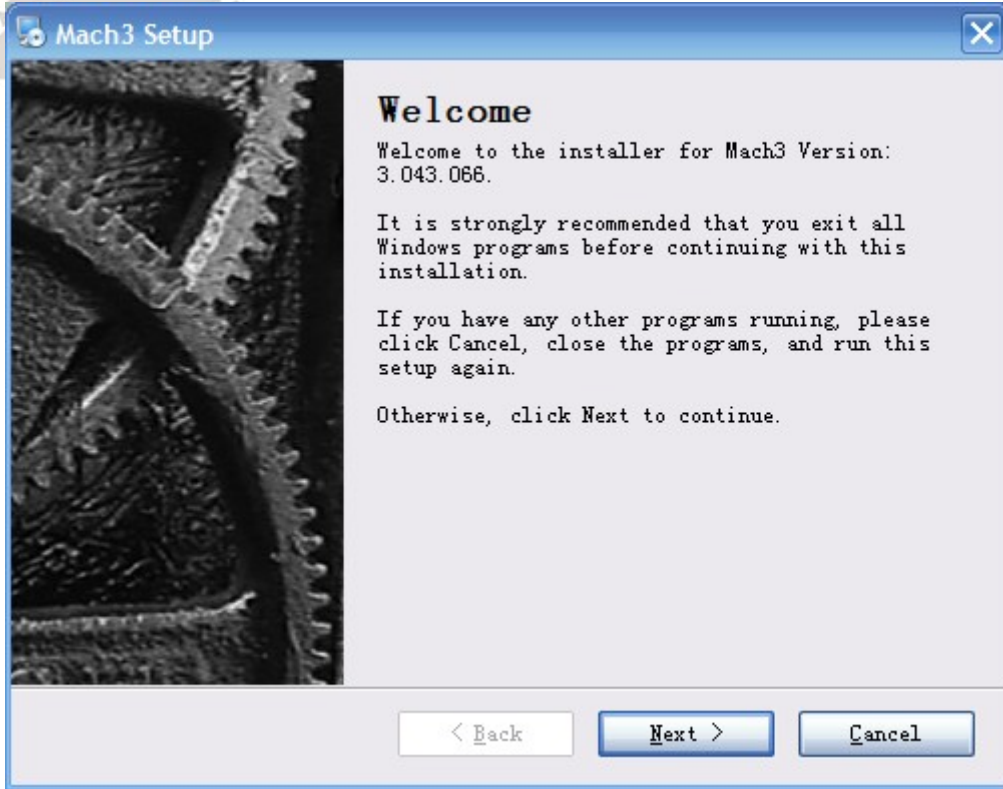

Figure3-2. MACH3 installation process 1

Click Next and then enter the page shown in Figure 3-3

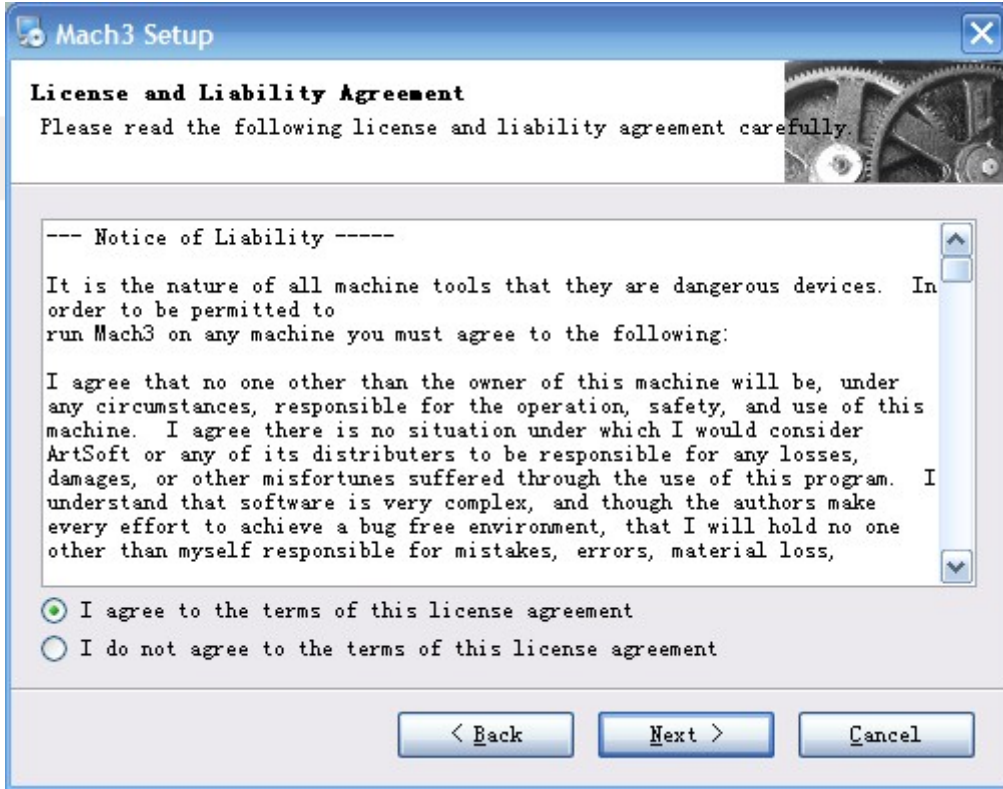

Figure3-3. installation process 2

Select I agree and click Next, See as Figure 3-4.



Figure3-4. MACH3 installation process 3

Select the installation path, click Next (it can be installed on any disk, and recommended to install the C drive or the D drive) See as Figure 3-5

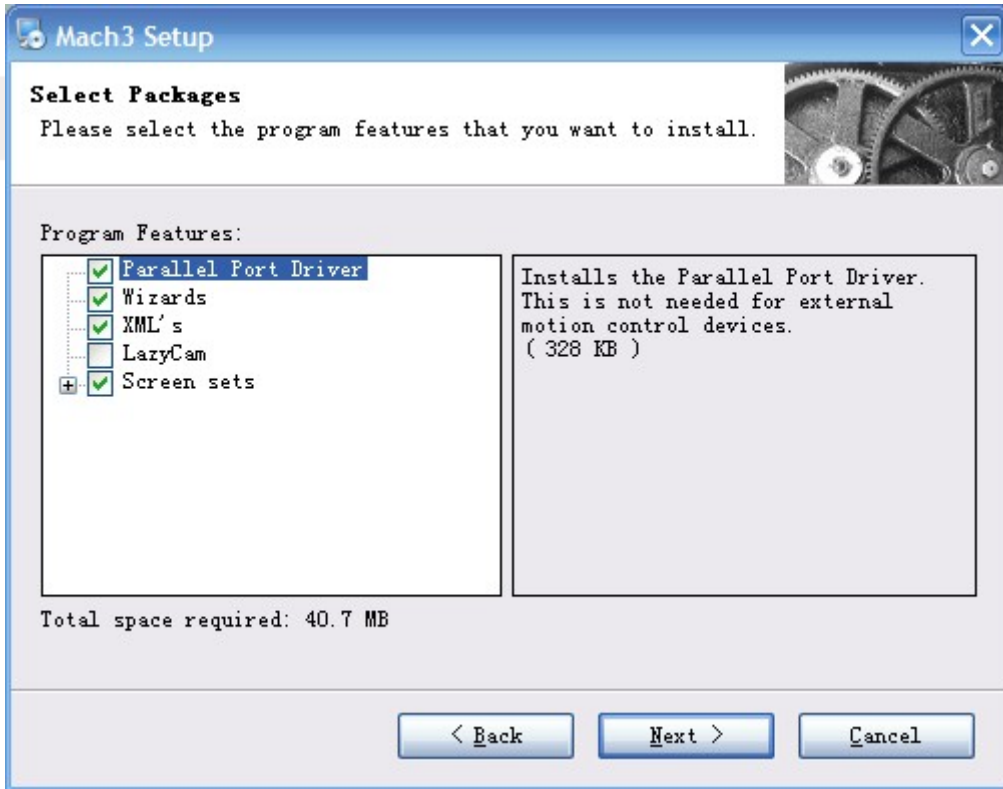

Figure3-5. MACH3 installation process 4

Click Next until completion. Then restart the computer.

3.2 MACH3 Registration



Copy the file Mach1Lic.dat in The CD-ROM to mach3 installation path (eg C:/MACH3).

3.3 NVUM Plug-in installation



Copy the file NOVUSUN.dll to X:\Mach3\PlugIns, X is the disk where the soft is installed.

Chapter 4. | Setting of software

4.1 Open software

Double-click the mach3mill



Enter mach3 software. Pop-up the plug-in dialog box. See as Figure 4-1.

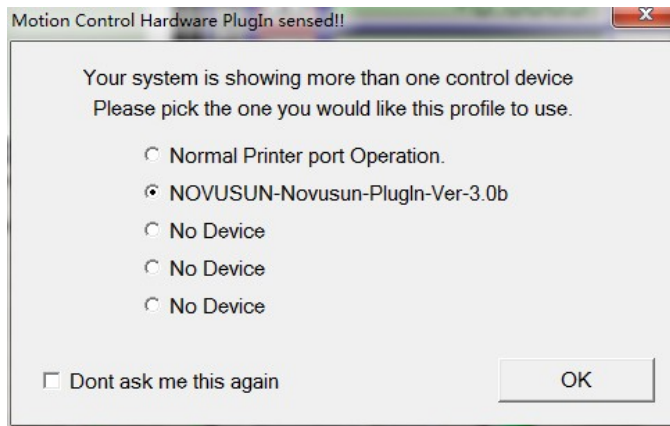

Figure4-1. Plugin selection dialog

Choose our plugin NOVUSUN-_Novusun-PlugIn---Ver-2.0a. Then press OK. If you do not want to the dialog box appear again next time, you can select Don't ask me this again.If connect successfully,Status bar will show "NVUM device is connected to your computer". See as Figure4-2.

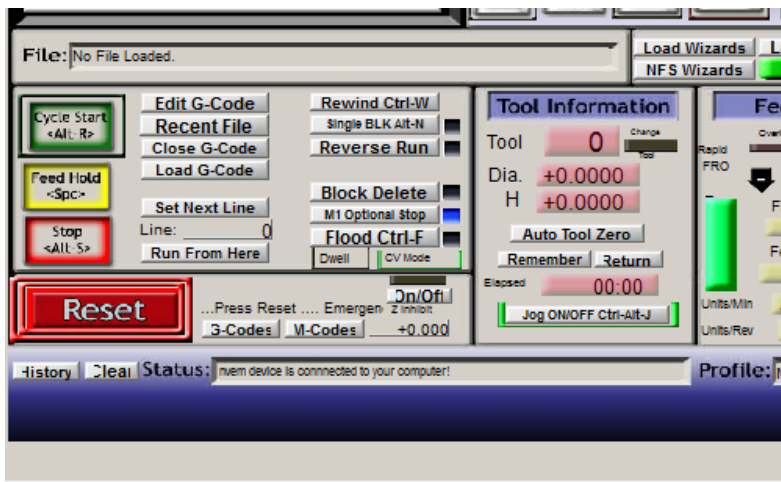

Figure4-2. connect successfully

4.2 Software Common settings

4.2.1 Check NVUM plugin

Click config plugins to input PluginConfig,you can seeNVUM. See as Figure4-4.

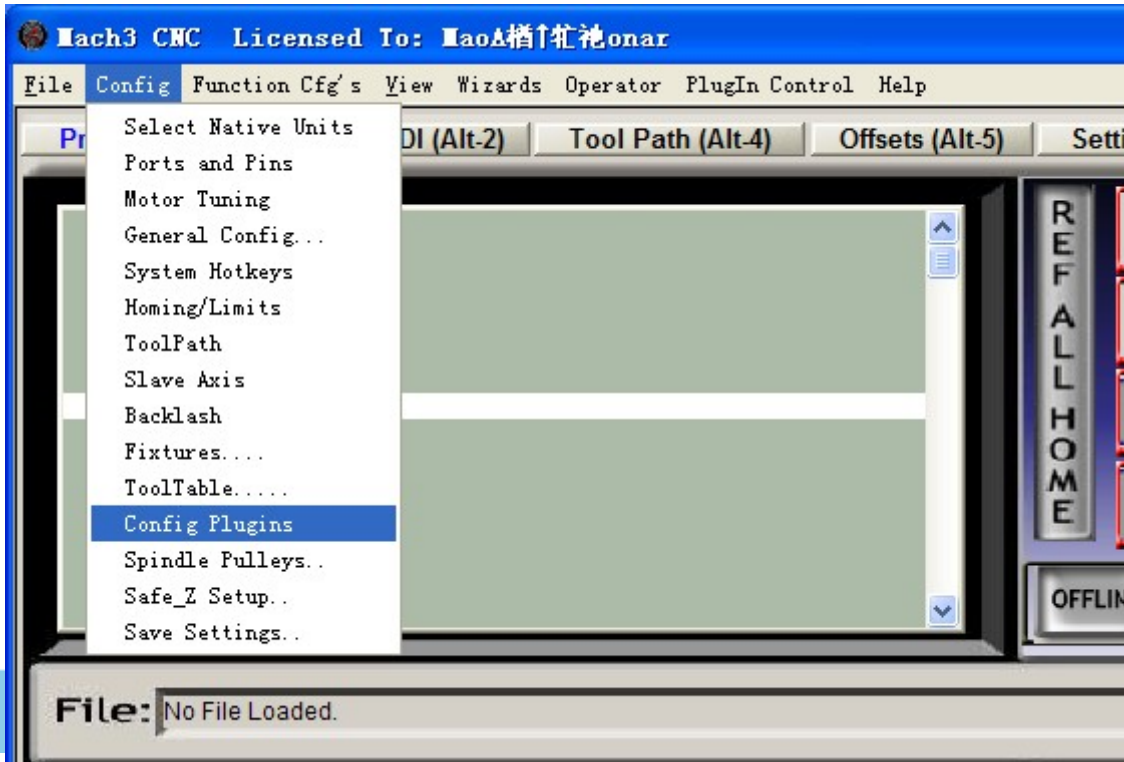

Figure4-3. Input Config plugins

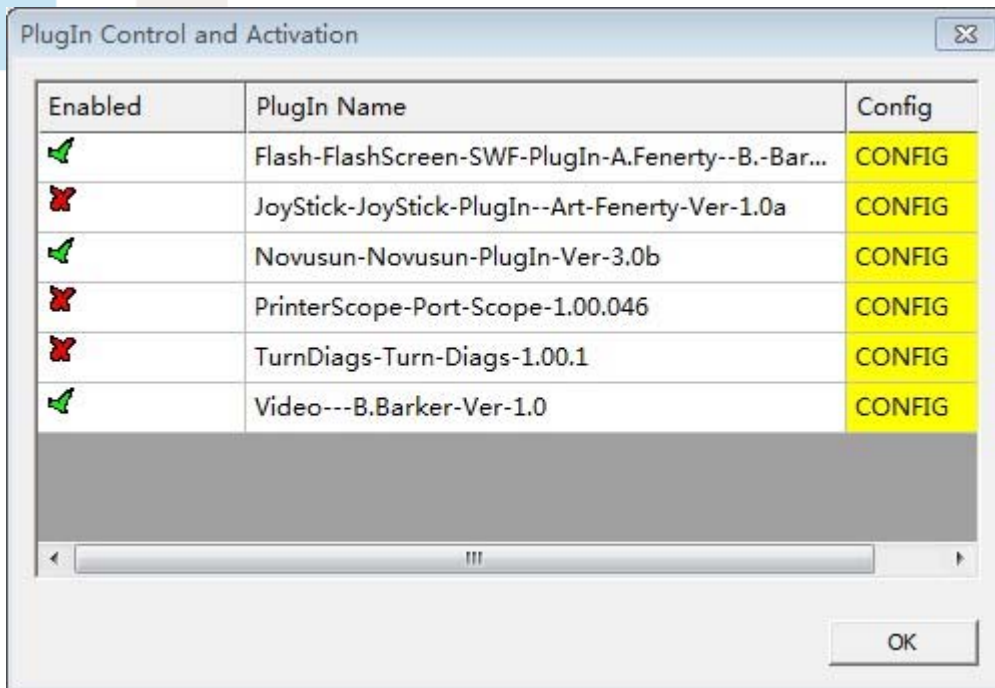

Figure4-4. MVUM Plugin

4.2.2 Motor operating parameters setting



Figure4-5. Motor operating parameter setting menu entry

See as Figure 4-5.From submenu “motor tuning” of the menu “config” into the motor parameter settings dialog. See as Figure 4-6

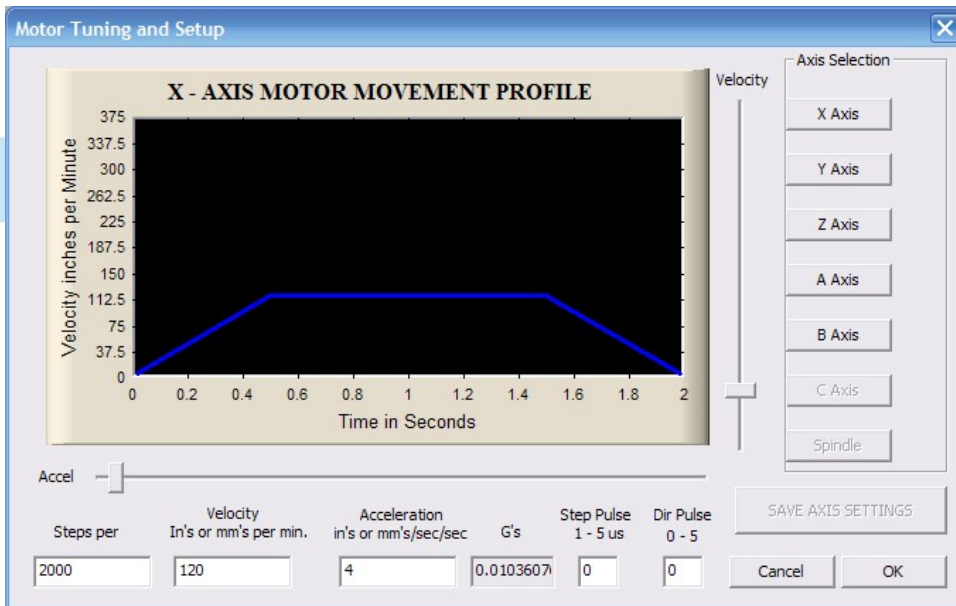

Figure4-6. Motor operating parameter settings dialog

The parameters are defined as follows:

Steps per: Pulse equivalent ,it is number of pulses required with axial movement 1mm, This can be calculated by lead screw pitch and motor drive segment. Such as pitch 2.5mm,2-phase

motor 8 segments, Calculation method is $8 \times 200 / 2.5 = 640$.

Velocity: The speed is the axial velocity, Units is mm/s, Recommended settings 1500.

Acceleration: Units is mm/s², Recommended settings 200.

Step Pulse: Step Pulse Cannot be set, it's 2.5us in default.

Dir Pulse: . Dir Pulse Cannot be set, it's 2.5us in default.

Attention: The parameters for each axis is not necessarily the same, To select the axis, and then set parameters. You should click “SAVE AXIS SETTINGS” After setting.

4.2.3 Port Settings

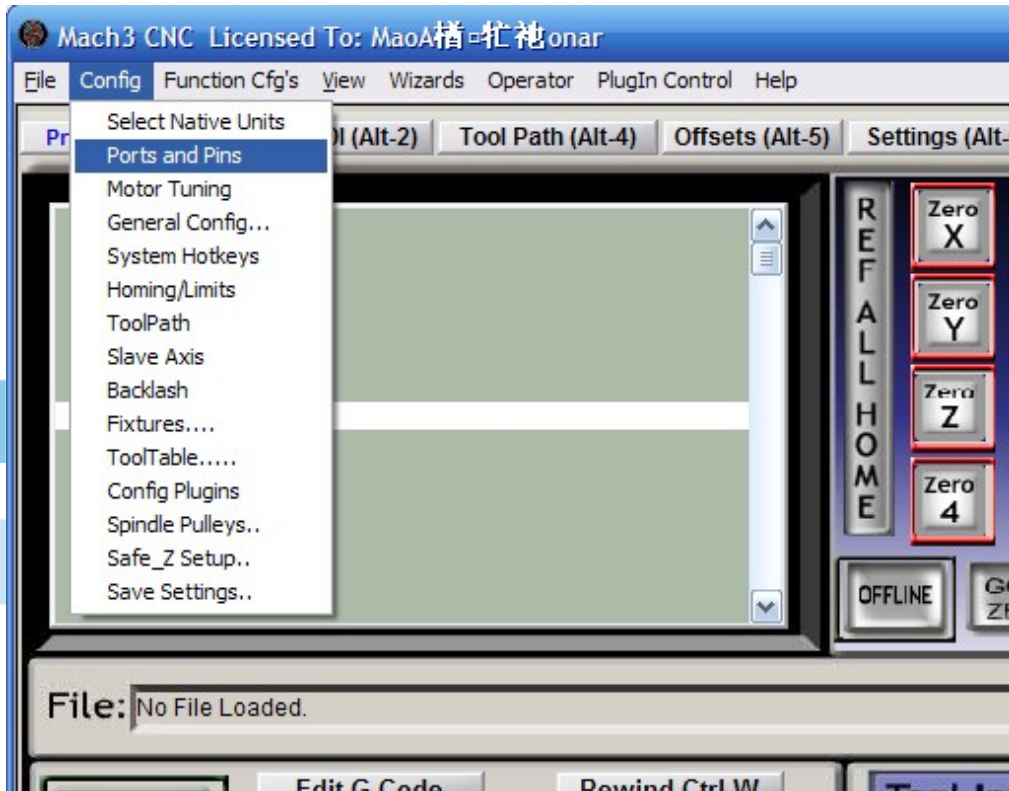

Figure4-7. Port setting intry

See as Figure 4-7, Click the sub-menu “ports and pins” of menu “Config” into Port Settings dialog box.

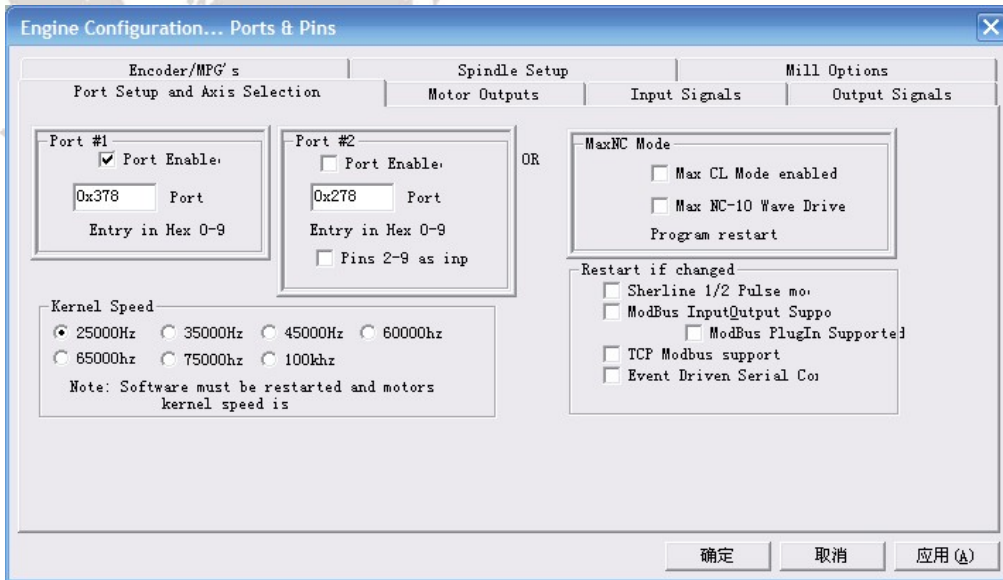

Figure4-8. Pin&Port Dialog

The sub-pages you need to set include “Motor Outputs”, “Input Signals”, “Output Signals” and “Spindle Setup”. First Click to enter “Motor Outputs”. This page is to select the stepper motor control pin. Because our usbmach3 interface board stepper motor signals are fixed, So here only need to Select, no need to select the specific pin. See as Figure4-9

To make the Z axis to the same direction, Z axis’s “Dir low” should be set to “√”. Other axes’s should be set as system need.

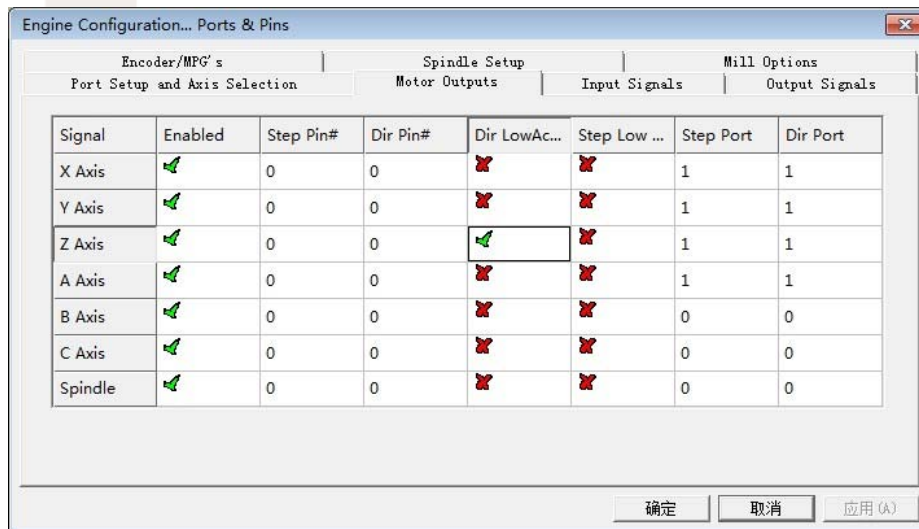

Figure4-9. Stepper motor port settings dialog

Click “Input Signals” Into the input signal settings page. See as Figure4-10

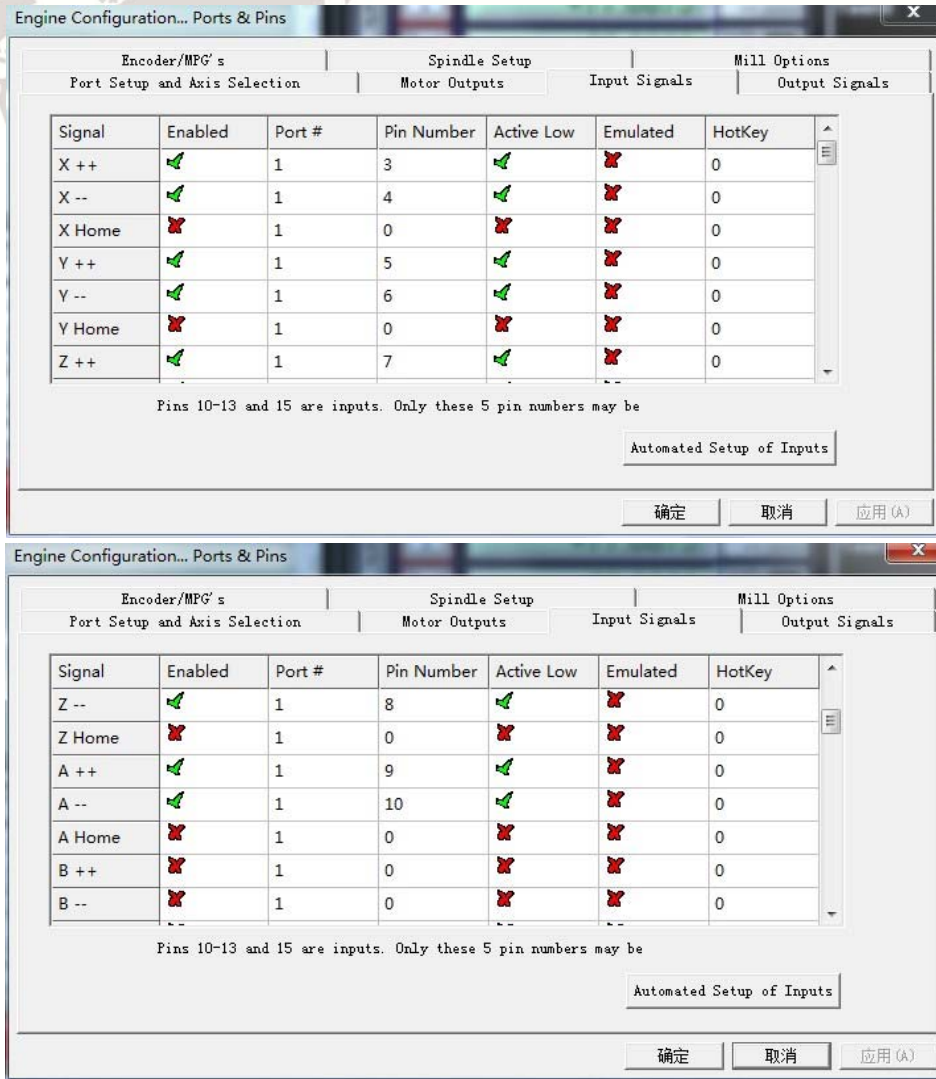

Figure4-10. limited Input Settings dialog

Here you can configure according to your actual needs the corresponding function. Optional Function include XYZABC6axis's Upper and lower limit、XYZABC6axis's HOME point.

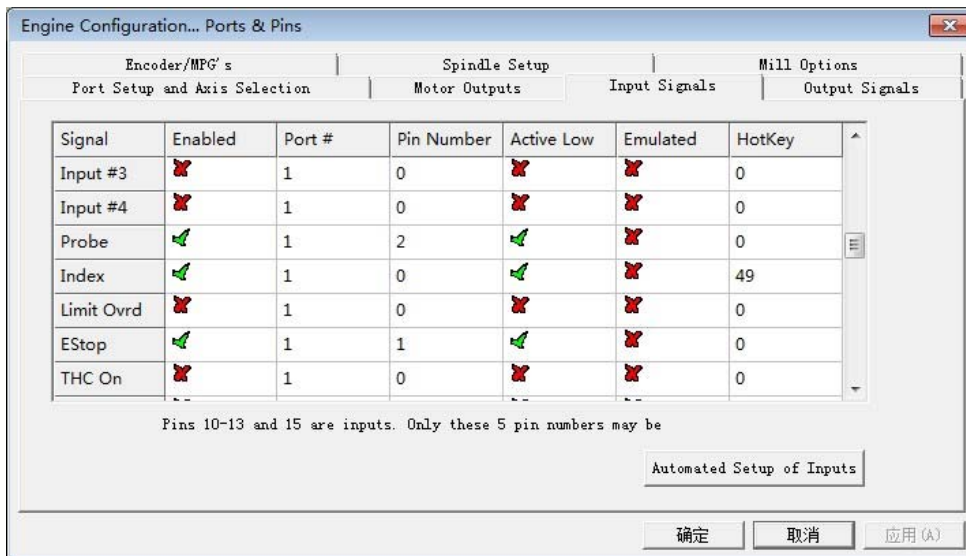

Figure4-11. Estop Probe and index Setting dialog

PROBE、ESTOP and Spindle speed back index Setting see as Figure 4-11, PIN of index

should be set to 0, and probe's pin number is 2, estop's pin number is 1.

Click "Output Signals" to enter the Output signal setting page. See as Figure 4-12

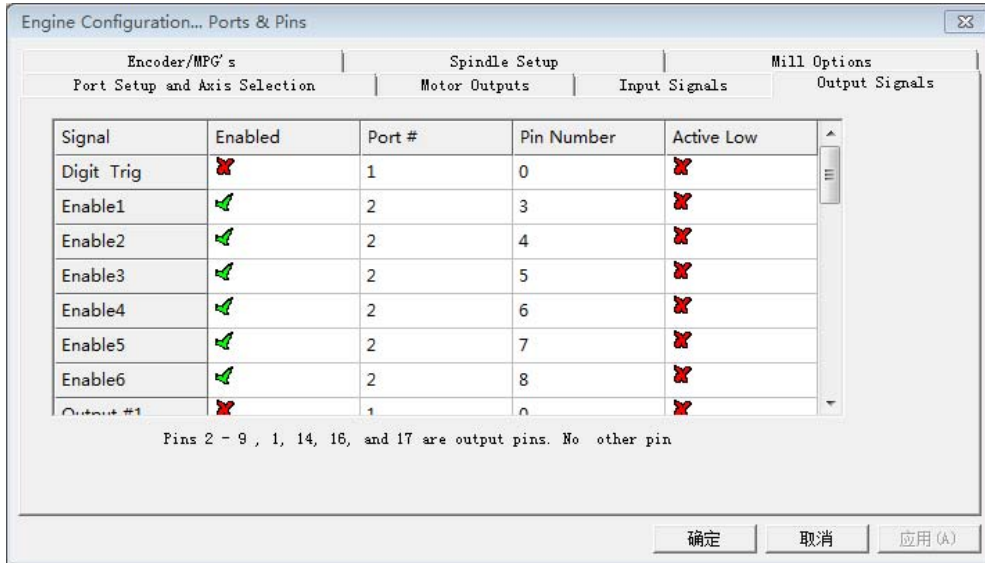

Figure4-12. Output Signal Setup dialog

Note that the output signal number from 1-16. Because there is an overlap with the input signal, We set output signals to the port 2. See as Figure4-12, PORT # All output signal is set to 2. Please put Output signal to the corresponding options as you need.

Click "Spindle Setup" switch to the spindle settings page. See as Figure4-13.

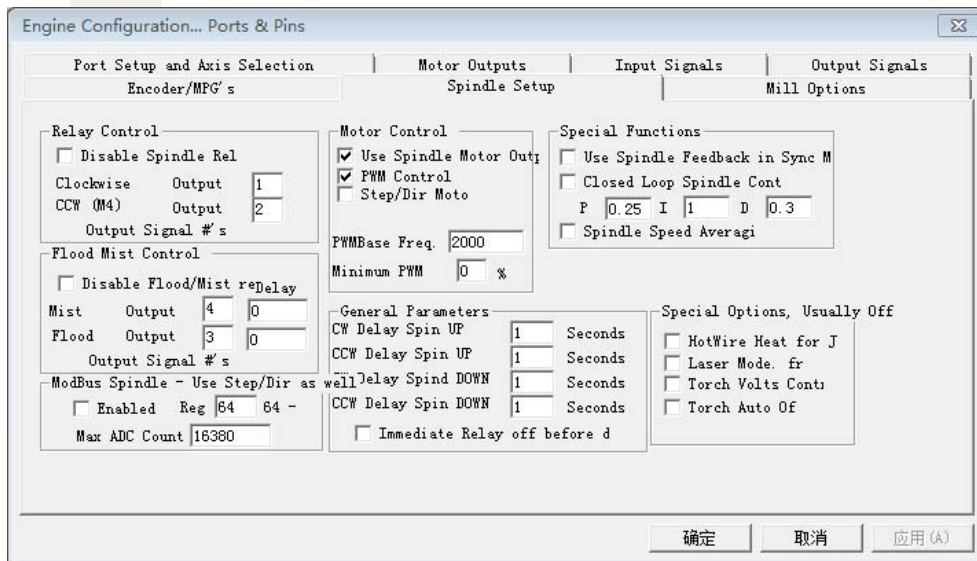

Figure4-13. Spindle Settings dialog

Here we can configure the spindle rotates CW、Reverse CCW、Mist、Flood pin, See as Figure4-13, They have been configured as 1、2、3、4. Corresponding to output#1~output#4 in

Figure4-14.output#1~output#6 in Output Signal Setup dialog can be Configured into these 4 signals. Here we only configure CW and CCW.CW is controlled by OUT1 and CCW is controlled by OUT2. Here we note correspondence between 2 page. Please select “use spindle motor output” if required PWM speed spindle. And select “ PWM Control”. Our PWM pin fixedly arranged on a special pin, it’s no need to be set.



Figure4-14. Spindle setting corresponds to the output configuration

4.2.4 MPG Settings

First we have to choose the type of MPG, refer to figure 4-12, and enter the plug-in configuration page. NVMPG or standard MPG can be selected in the plug-in page. Figure 4-12 chooses the standard MPG by default

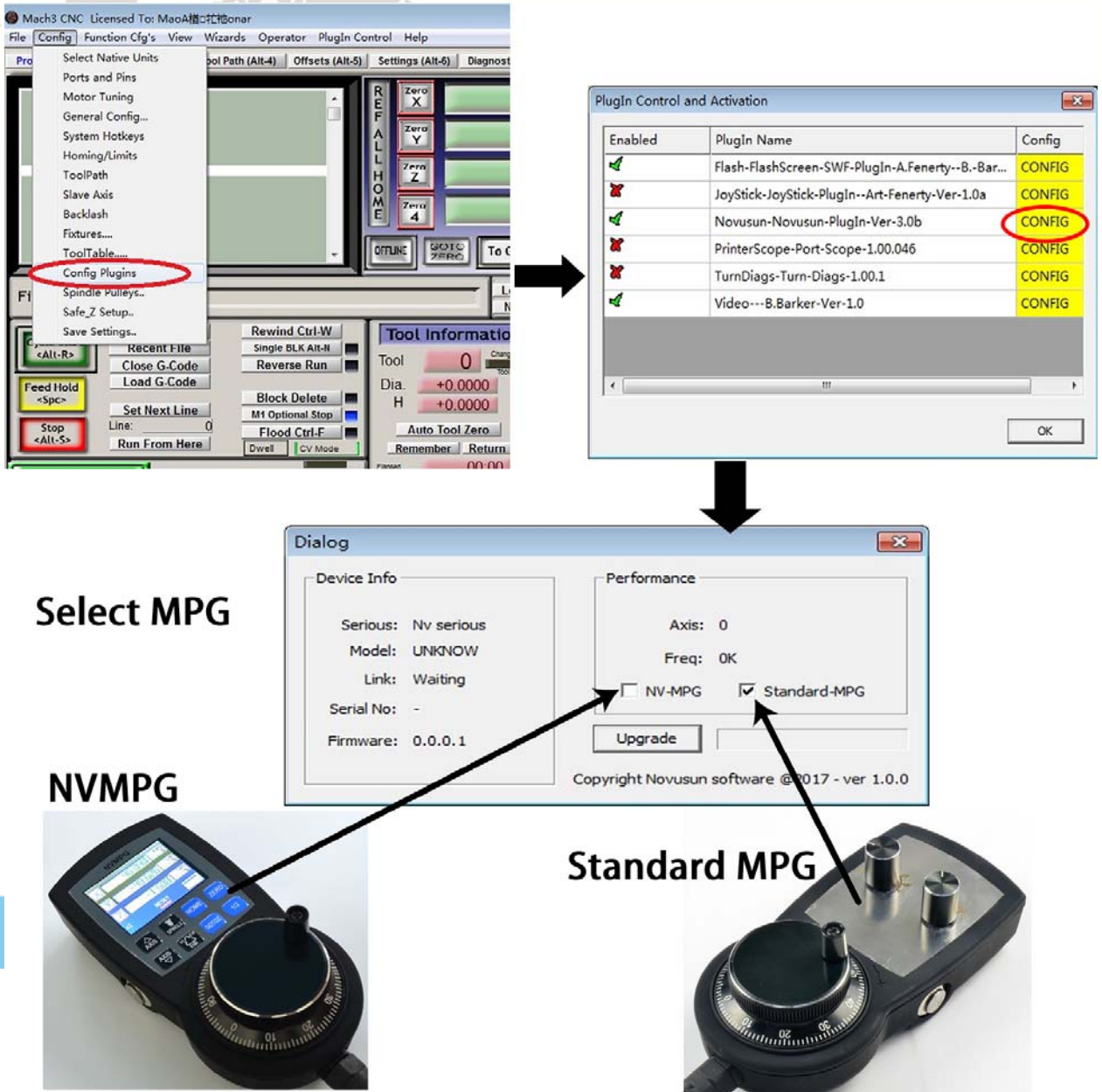

Figure4-1. MPG configuration

The second step is to open the MPG of Mach3, as in Figure 4-13

Port Setup and Axis Selection Encoder/MPG's		Motor Outputs Spindle Setup		Input Signals		Output Signals Mill Options	
Signal	Enabled	A -Port #	A -Pin #	B -Port #	B -Pin #	Counts/...	Velocity
Encoder1		0	0	0	0	1.000000	100.0000...
Encoder2		0	0	0	0	1.000000	100.0000...
Encoder3		0	0	0	0	1.000000	100.0000...
Encoder4		0	0	0	0	1.000000	100.0000...
MPG #1		0	0	0	0	1.000000	100.0000...
MPG #2		0	0	0	0	1.000000	100.0000...
MPG #3		0	0	0	0	1.000000	100.0000...

Figure4-2. Open MPG

The third step is to change to MPG mode on the MPG panel , you can use the hand pulse, under the main page, click TAB to open MPG panel, refer to figure 4-14



Figure4-3. Change to MPG mode on MPG panel

Chapter 5. Using of software

5.1 Set Machine Coordinate system

Firstly Open the software,as the drawing 5-1 shows,at this time,the software can operate the machine movements,but before the setting machine coordinate system,there is no connection between the software and machine.So first step is to set the machine coordinate system.

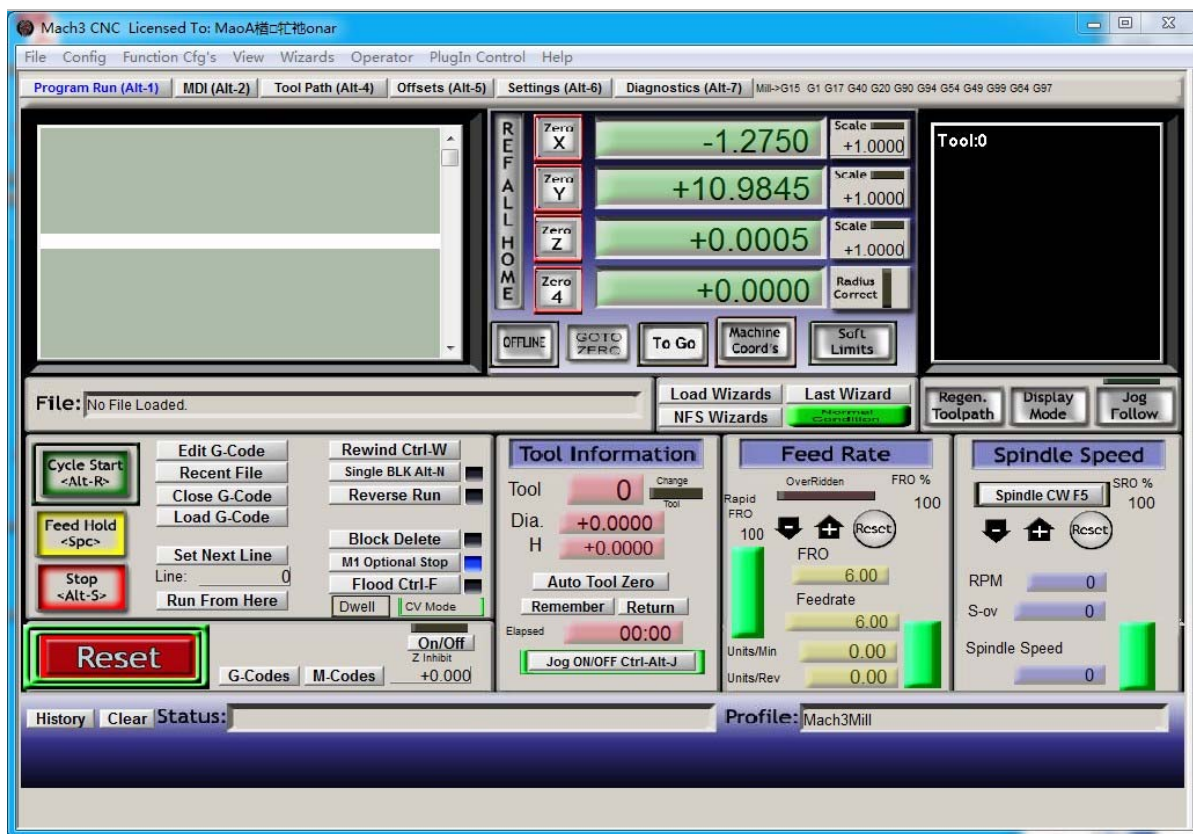

Figure5-1. Main Screen of mach3

1、Set the machine original position switch

As our request,some machine set the original point at the coordinate positive direction,some machines set the original point at the coordinate negative direction.Mach 3 can search out the machine original point direction by the software setting.As the pic 5-2 shows,open Homing on the config menu.Then as pic 5-3 shows.On this page,Home Neg is for searching for the machine

original point direction, × means searching original point at negative direction; √ means searching original points at the positive direction. As the picture 5-3 shows, X axis's original position is at the negative direction, Y and Z's original points are at the positive direction.

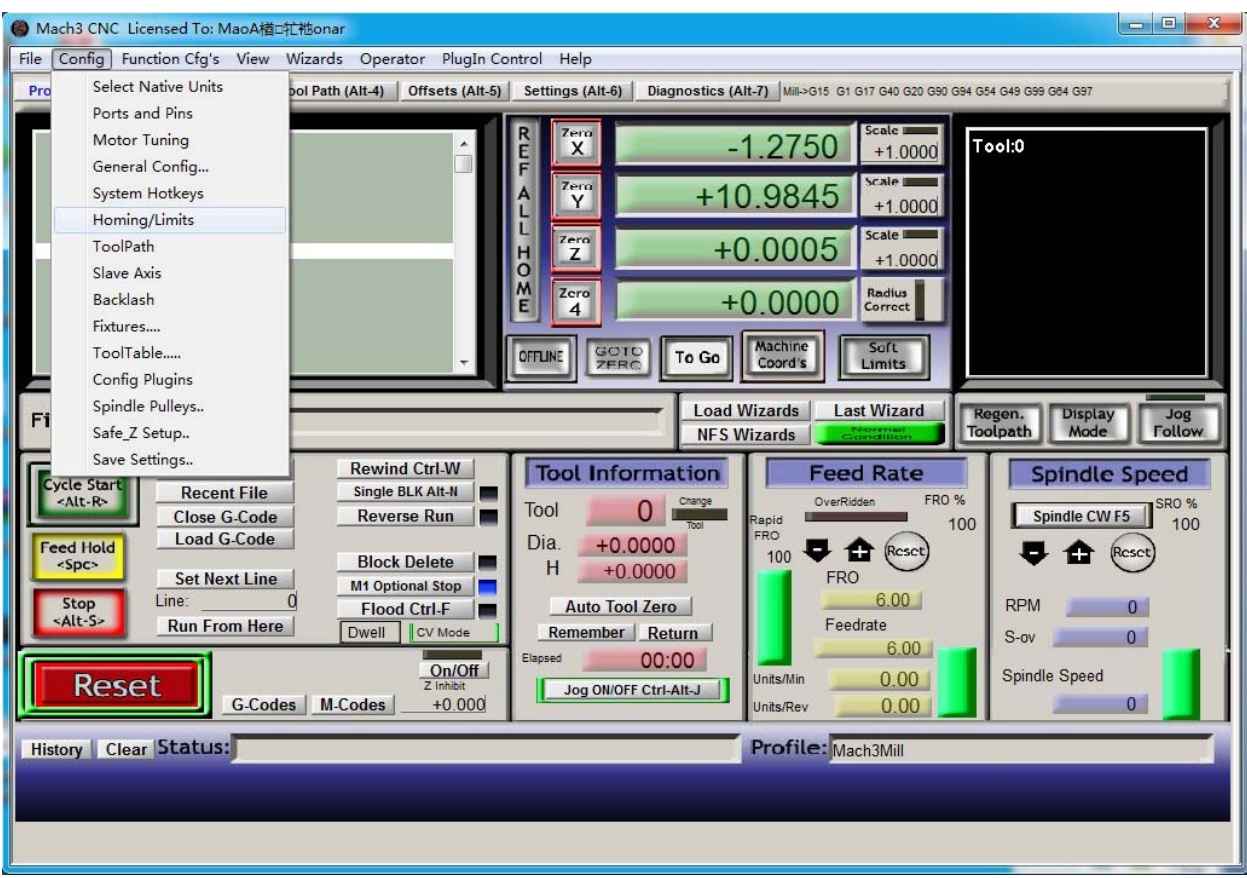

Figure5-2. Click homing of Config

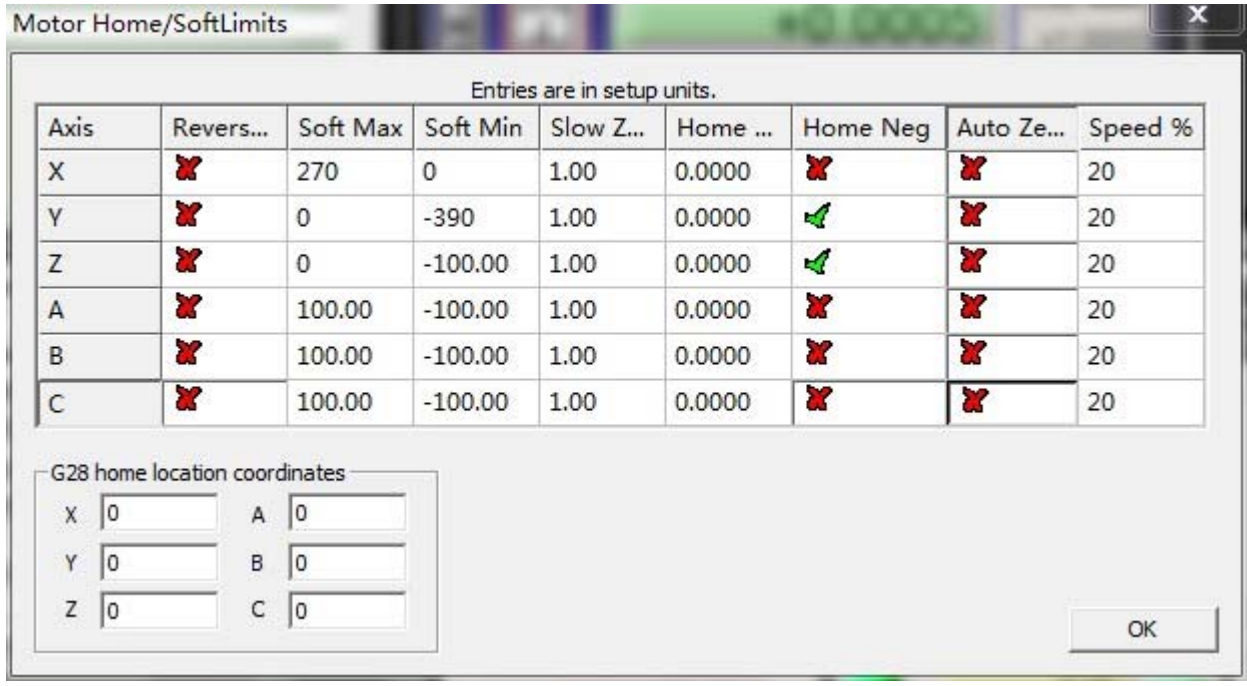

Figure5-3. Motor Home and Softlimits dialog

2、Set soft limits

As Figure 5-3 shows, this page also can set machine soft limit points, Soft Max is positive direction soft limited points, soft Min is negative direction soft limited points. The soft limited points values is according the references to the machine coordinate system, so as this example shows, Y and Z axis's max value is 0, all the effective coordinate data is less than 0. As the Figure shows, according to our current request, we set our XYZ axis soft limited points area as [0,270] [-390,0] [-100,0].

3、 Searching for machine original points

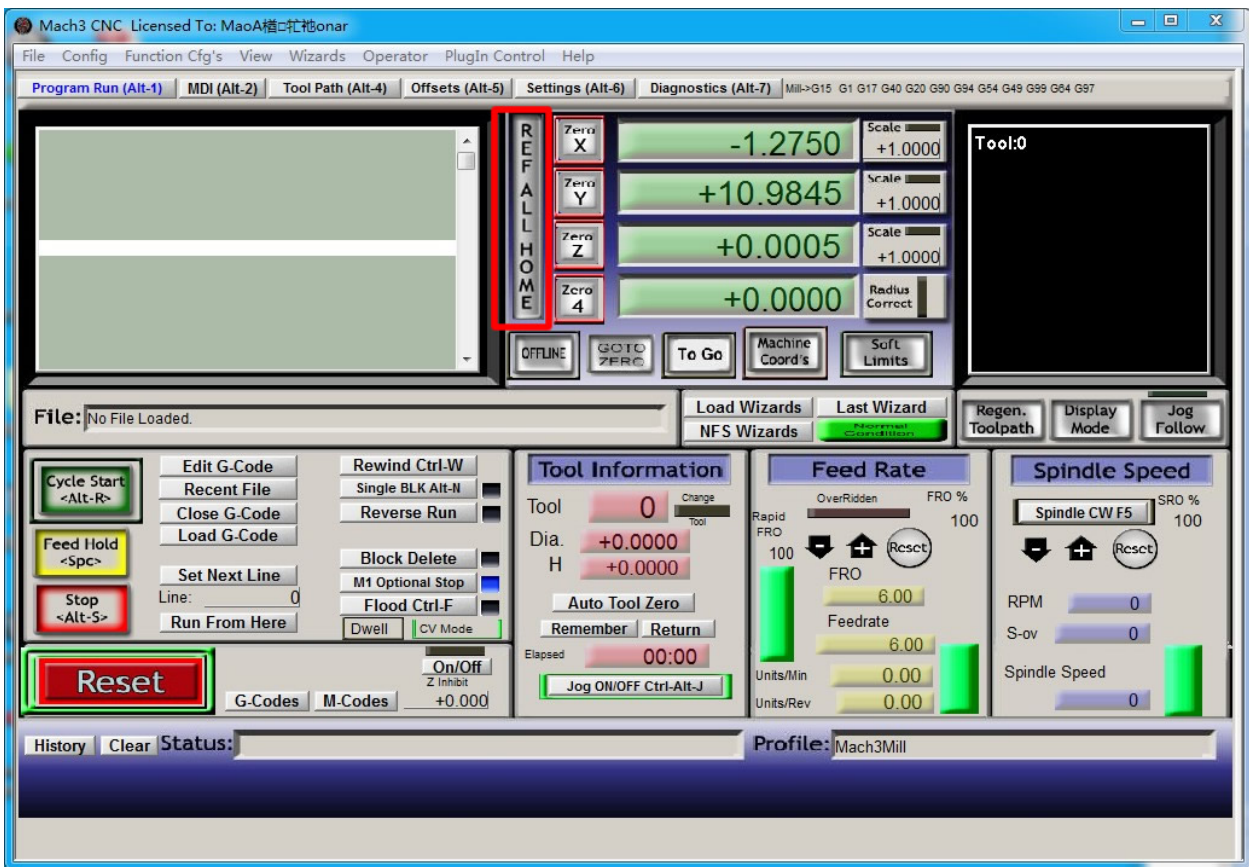

Figure 5-4. Click REF ALL HOME to HOME all axis

As Figure 5-4 shows, press REF ALL HOME at main display page, then XYZ A4 start to search for the original points, if you need more axis's operation, edit macro command, or press Alt+7 into Diagnostics display page, you can search original point for every axis. Diagnostics

5.2 Set workpiece coordinate system

Because every working material is hold in different position on the machine, we need to set

one or more workpiece coordinate system.

1、 Move to current working piece 0 point

Firstly hold down the material,use keyboard or pendant to move tool tip at the 0 point,so this 0 point is the working piece 0 point,it related with the working G code file,so the user must be very familiar to his own working G code.As our example shows,the 0 point is on the center of the working piece surface,so we just move the tool tip to this position.

2、 clear Coordinate

As 5-5 shows,press Zero button on each axis, then clear to 0 for each axis.After operation,the result shows as Figure 5-6.

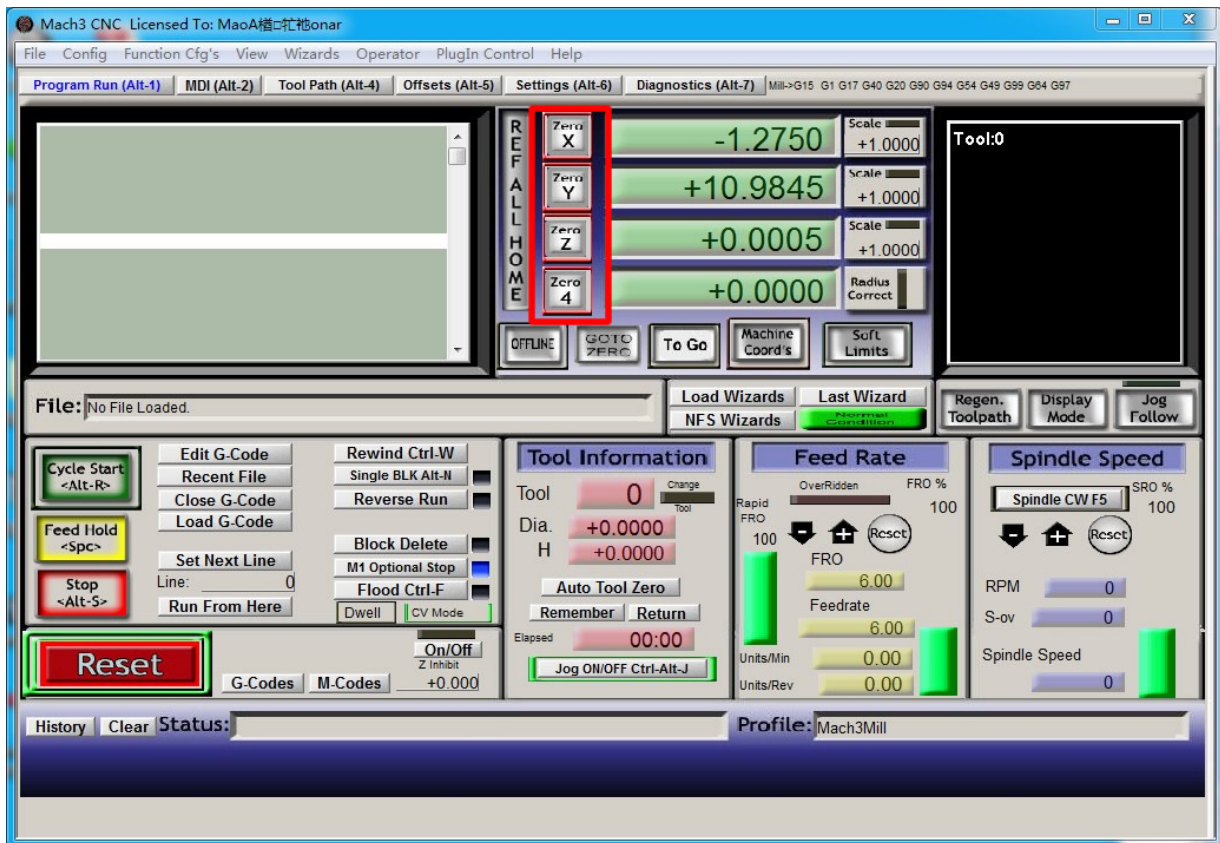

Figure5-5. Press Zero on each axis,all clear to 0

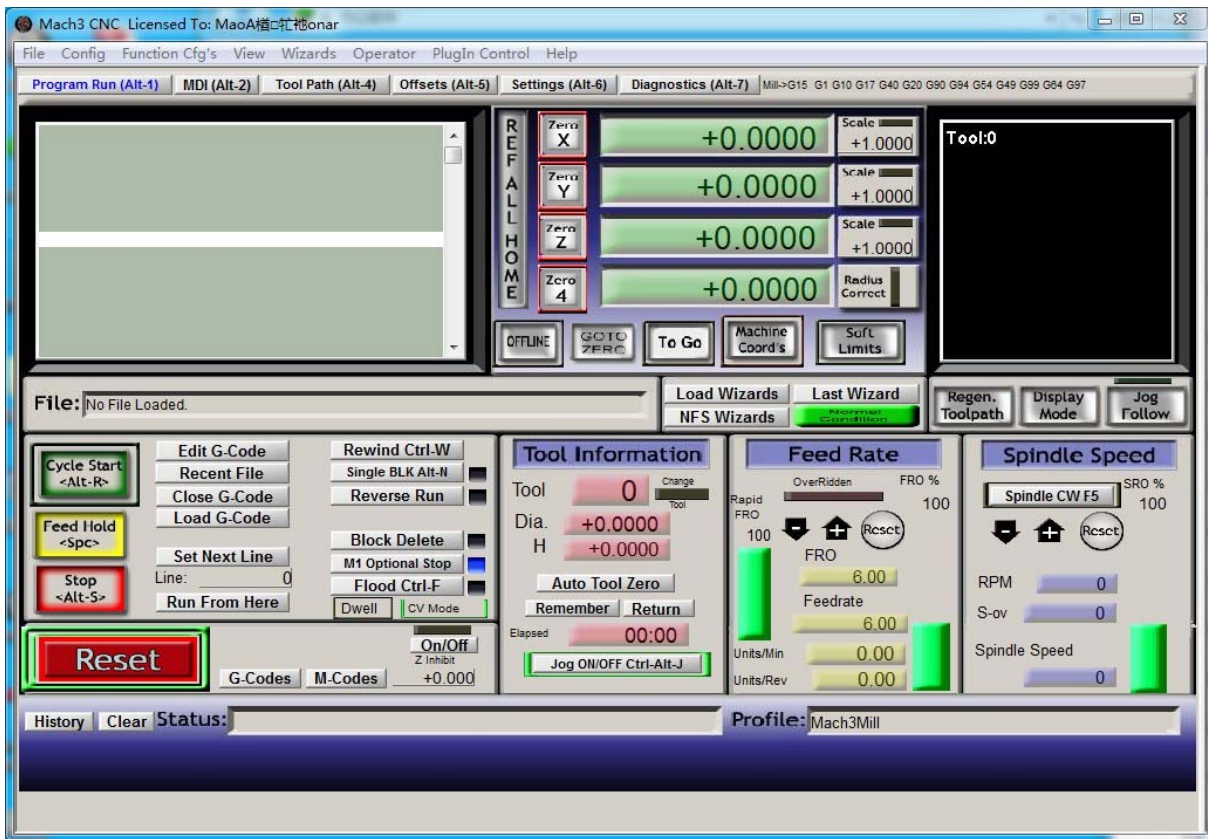

Figure5-6. Main Screen after ZERO all axis

5.3 Open G code file and run

As Figure 5-7 shows,press “load G code” button at the main page or open “Load G code” at main menu “File”,open your G code.It displayed as Figure 5-8 showing,then press button “cycle start” then machine start to work.

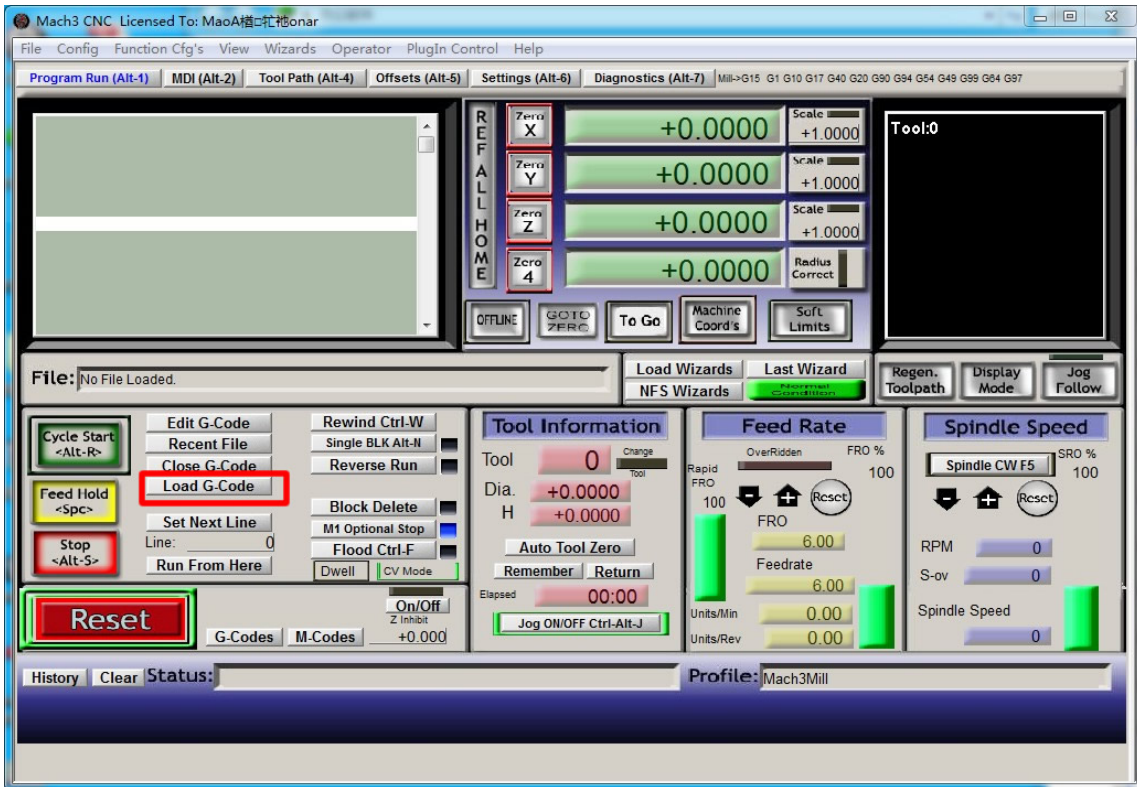

Figure5-7. Press Load G-Code and open your G code

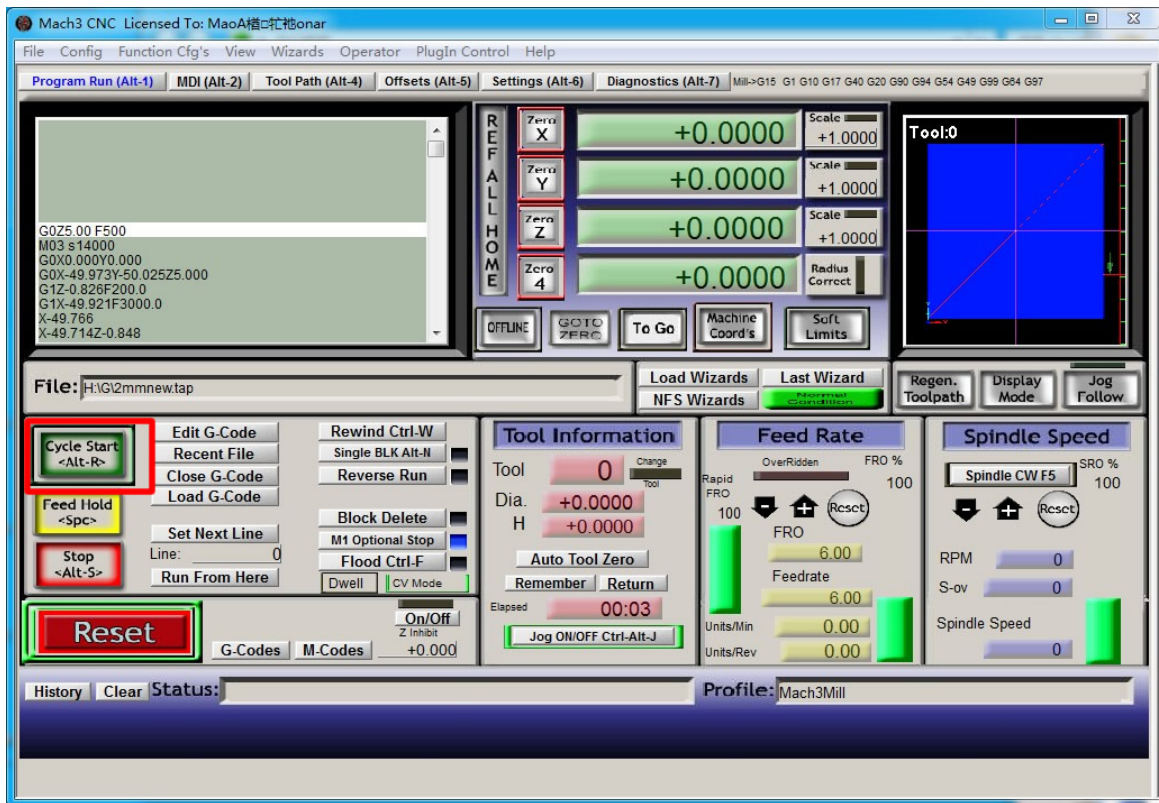

Figure5-8. After opening G code,press "Cycle Start" and start to work



Chapter 6 | Question & Answer

6.1 Q&A for Hardware

6.2 Q&A for Software

➤➤ Chapter 7. Contract us

- ☒ Website: WWW.NVCNC.COM
- ☒ Support Email: Support@nvcnc.com